

ACS 2000 Single-channel Controller

Design: www.axess.fr - Publication: Alcatel Vacuum Technology France - Reference: 113161 - Ed 02 - Date: 09/2007

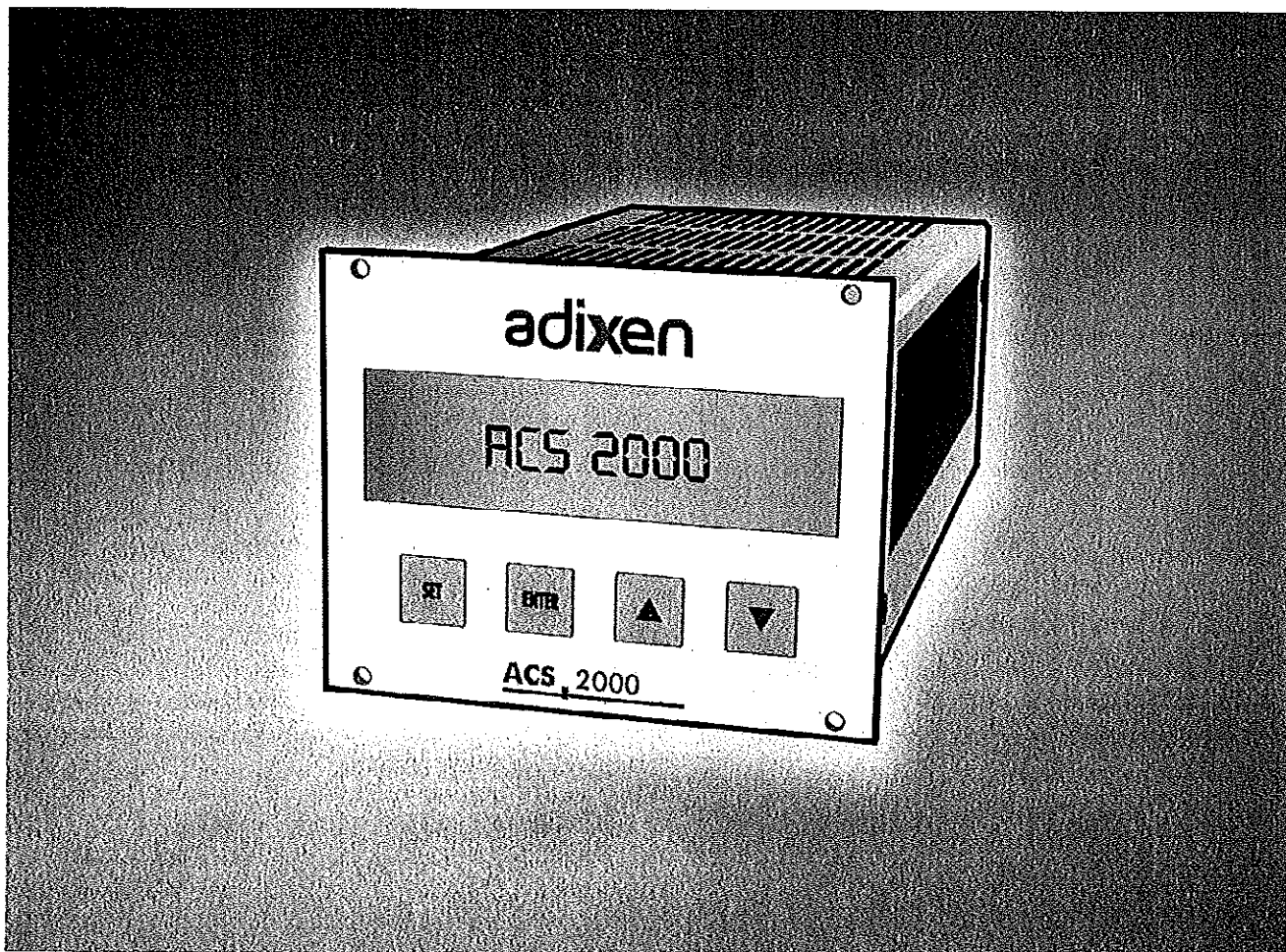

User's Manual

adixen
by Alcatel Vacuum Technology

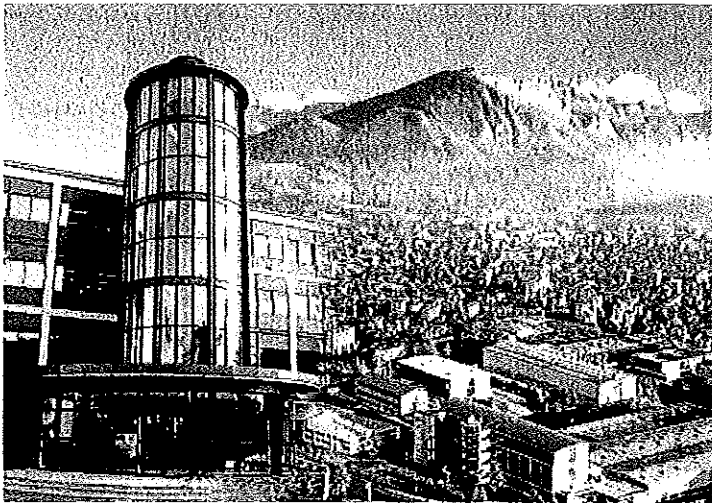

Alcatel Vacuum Technology, as part of the Alcatel-Lucent Group, has been supplying vacuum pumps, helium and hydrogen leak detection systems, plasma sensors, vacuum measurement for several years.

Thanks to its complete range of products, the company has become an essential player in multiple applications : instrumentation, Research & Development, industry and semiconductors. Alcatel Vacuum Technology has launched Adixen, its new brand name, in recognition of the company's international standing in vacuum position.

With both ISO 9001 and 14001 certifications, the French company is an acknowledged expert in service and support, and Adixen products have the highest quality and environmental standards.

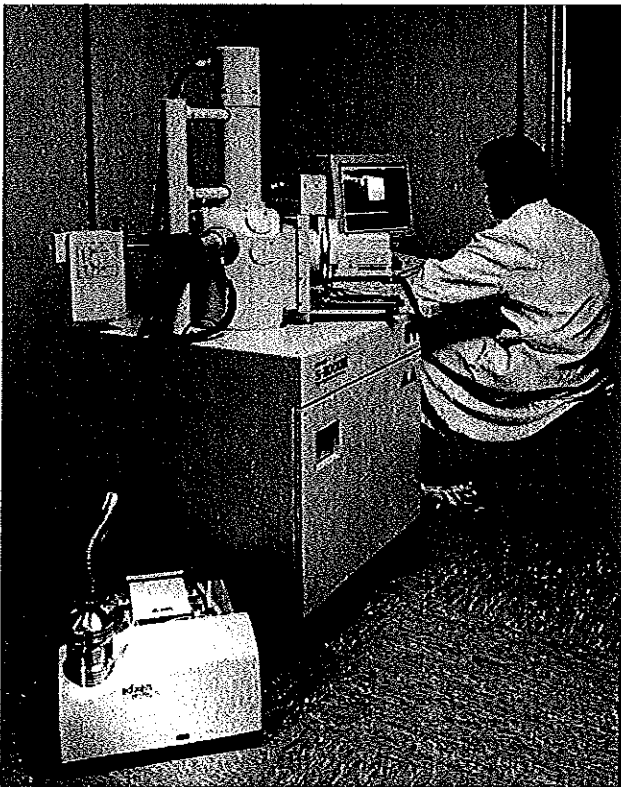

With 45 years of experience, AVT today has a worldwide presence, through its international network that includes a whole host of experienced subsidiaries, distributors and agents.

The first step was the founding of Alcatel Vacuum Products (Hingham- MA) in the United States, thirty years ago, reinforced today by 2 others US subsidiaries in Fremont (CA) and Tempe (AZ).

In Europe, AVTF-France headquarters and its subsidiaries, Alcatel Hochvakuumtechnik (Germany), Alcatel Vacuum Technology UK (Scotland), Alcatel Vacuum Technology Benelux (Netherlands), Alcatel Vacuum Systems (Italy) and more recently Adixen Sensistor AB in Sweden (in 2007) form the foundation for the European partner network.

In Asia, our presence started in 1993 with Alcatel Vacuum Technology (Japan), and has been strengthened with Alcatel Vacuum Technology Korea (in 1995), Alcatel Vacuum Technology Taiwan (in 2001), Alcatel Vacuum Technology Singapore, Alcatel Vacuum Technology Shanghai (China) (in 2004)

This organization is rounded off by more than 40 representatives based in a variety of continents.

Thus, whatever the circumstances, the users of Adixen products can always rely on quick support of our specialists in Vacuum Technology.

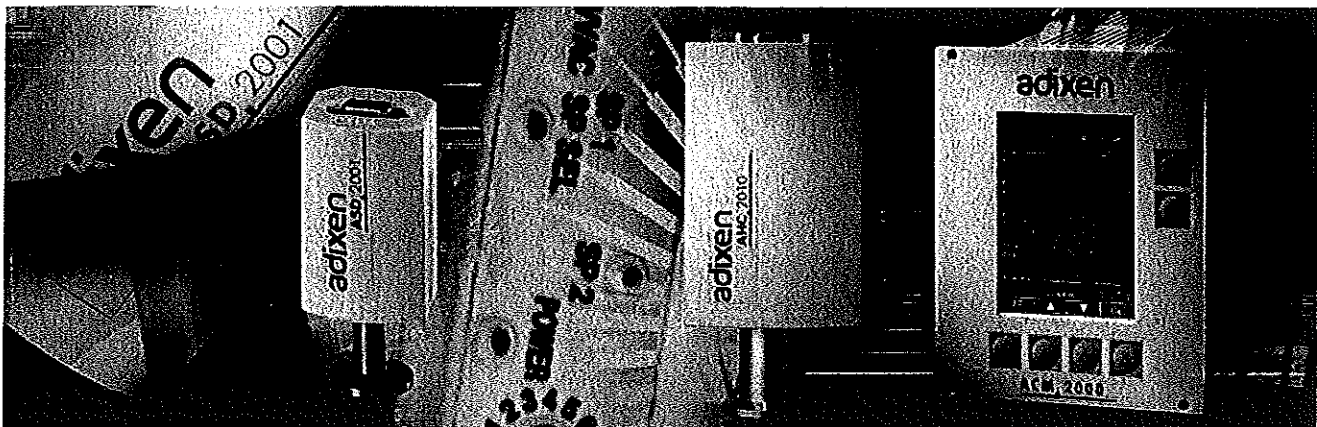

ACS 2000 Single-channel controller

Welcome

Dear customer,

You have just acquired an Adixen ACS 2000 controller. We thank you for your purchase and are proud to be able to count you among our customers.

Alcatel Vacuum Technology has acquired a vast wealth of experience in the design of controllers over the year.

To guarantee optimum performance and full satisfaction in using this equipment, please take the necessary time to become familiar with this manual before carrying out any operation, especially the section covering installation and commissioning, before installing or operating this controller.

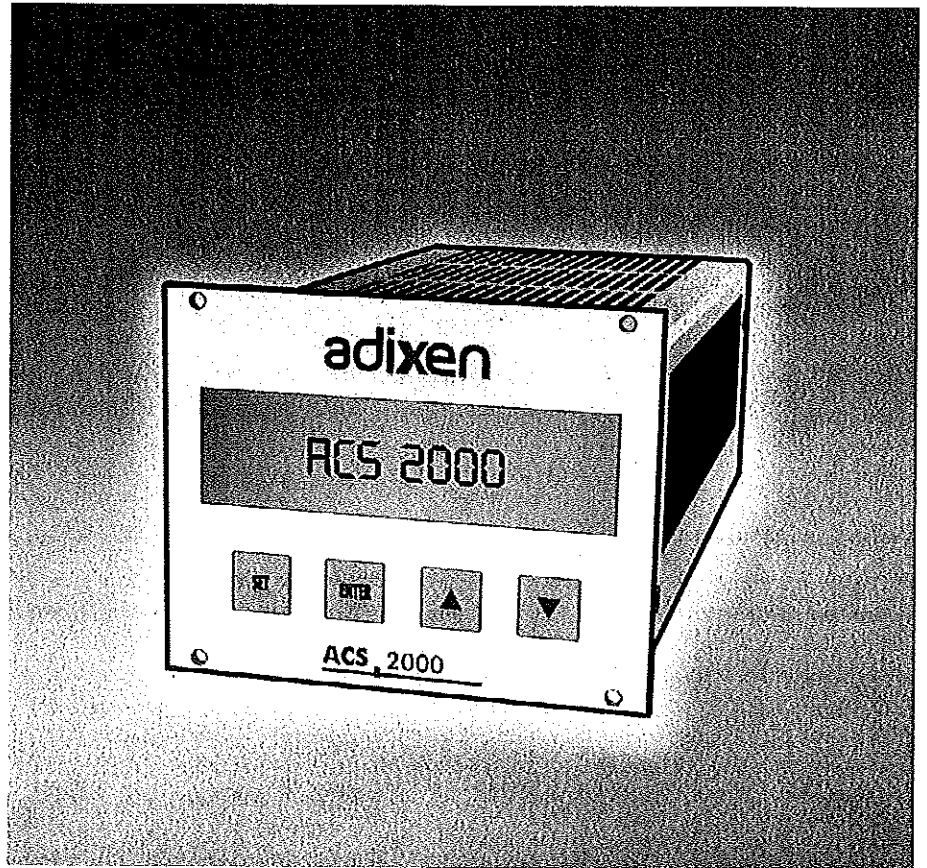

The ACS 2000 is a single-channel controller designed to work with the following gauges:

- PIRANI gauge: AP 2004
- Combined PIRANI/Cold cathode gauge: ACC 2009
- Combined CRYSTAL/Hot cathode gauge: AHC 2010
- Capacitive gauges: ASD 200X series, ARD 200X series

ACS 2000 Single-channel controller

This product meets all the essential requirements contained in European directives and standards, as listed in the Declaration of Conformity shown in Appendix 9 of this manual. These Directives are amended by Directive 93/68/EEC (CE mark).

Copyright/Intellectual property:

The use of Adixen products are subject to copyright and intellectual property rights in force in any jurisdiction. All rights reserved, including copying this document in whole or any part without prior written authorization from Alcatel Vacuum Technology France.

Specifications and information are subject to change without notice by Alcatel Vacuum Technology France.

General contents

User's Manual

ACS 2000 Controller

Chapter A	<i>Commissioning</i>
<ul style="list-style-type: none">- General safety recommendations- Unpacking and storing the controller- Installation- Quick commissioning procedure	
Chapter B	<i>Product description</i>
<ul style="list-style-type: none">- Overview of the single-channel controller- Navigation controls	
Chapter C	<i>Settings</i>
<ul style="list-style-type: none">- Overview- Configuring the gauges- Set point management- General settings for the ACS 2000	
Chapter D	<i>Test mode</i>
<ul style="list-style-type: none">- Access to test mode- Software version checking- Analog/Digital converter test- Controller display test- Memory tests- Controller interface tests	
Chapter E	<i>RS232 mode</i>
<ul style="list-style-type: none">- Introduction- List of commands- Detailed description of RS232 command	
Chapter F	<i>Appendices</i>
<ul style="list-style-type: none">- Appendix 1: Technical characteristics- Appendix 2: Dimensions- Appendix 3: Rack Installation- Appendix 4: Cable and connector details- Appendix 5: Factory settings- Appendix 6: Error messages- Appendix 7: Accessories- Appendix 8: Conversion of measuring units- Appendix 9: Declaration of conformity- Appendix 10: Detailed example of navigation	

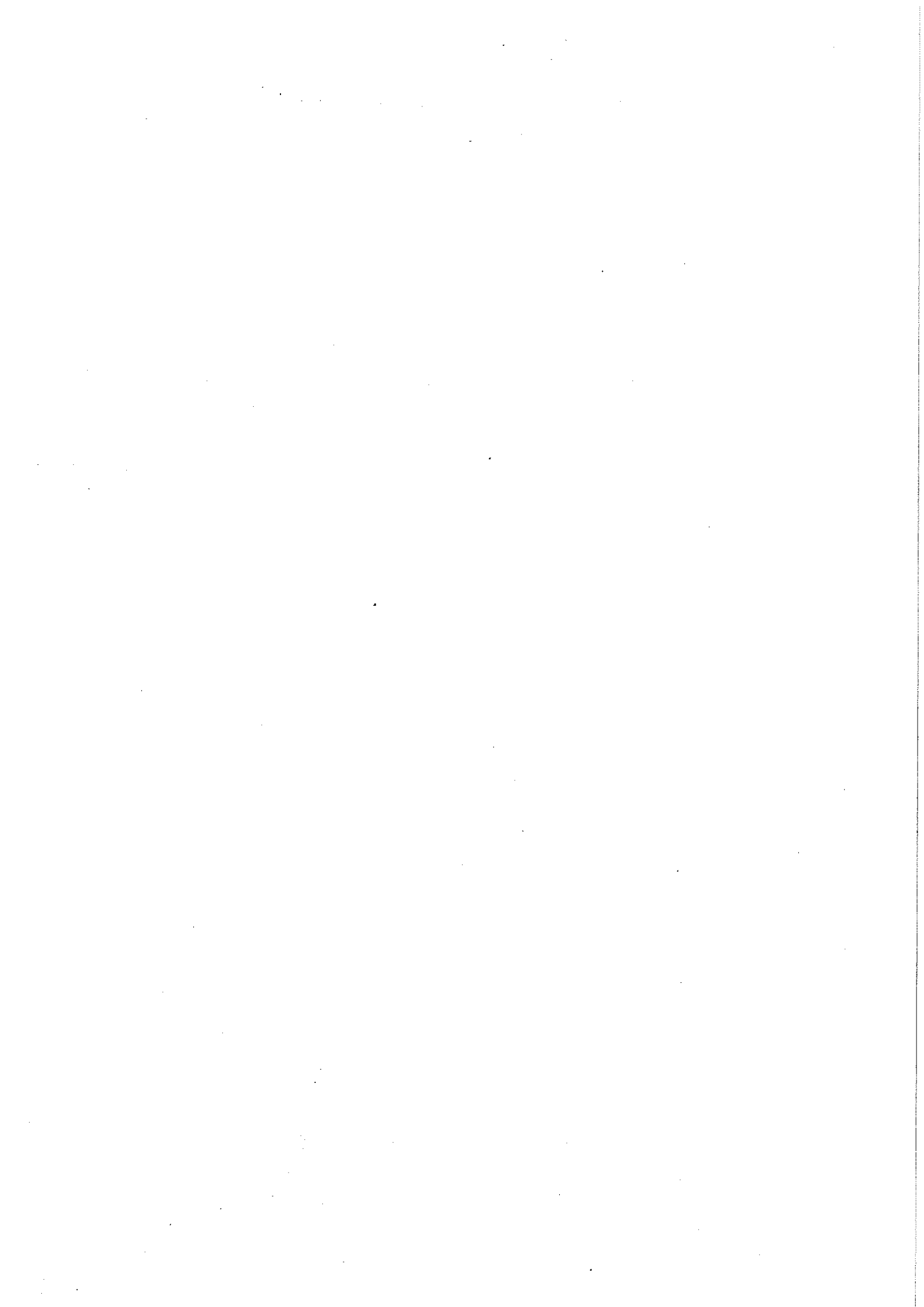

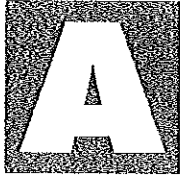

Commissioning

ACS 2000 User's Manual Detailed contents

General safety recommendations	2/9
Unpacking and storing the controller	5/9
<ul style="list-style-type: none">- Unpacking- Storing the controller- Decontamination - Product recycling	
Installation	6/9
<ul style="list-style-type: none">- Assembly, installation- Table mounting- Rack mounting- Power connections	
Quick commissioning procedure	7/9
<ul style="list-style-type: none">- Bringing the ACS 2000 on line- Start-up screen- Measurement screen and display- Warning or error message- Shutting down	

A	Commissioning
B	Product description
C	Settings
D	Test mode
E	RS232 mode
F	Appendices

General safety rules

This controller is designed to be completely safe to use. Nonetheless, there are certain risks that cannot be eliminated. Such risks are indicated throughout this manual by the following warning messages:

Warning symbols used in this manual

CAUTION	This type of warning is used to indicate a potential risk that can cause significant damage to equipment and/or installations if instructions are not followed.
⚠ CAUTION	This type of warning is used to indicate a potential risk that can cause minor injury if instructions are not followed.
⚠ WARNING	This type of warning is used to indicate a potential risk that can cause serious injury or death if instructions are not followed.
⚠ DANGER	This type of warning is used to indicate an imminent risk that can cause serious injury or death if instructions are not followed.

- A Commissioning
- B Product description
- C Settings
- D Test mode
- E RS232 mode
- F Appendices

General safety rules

Safety instructions for the installation

CAUTION

Before switching on the power to this controller, the user must be familiar with this manual and must follow the safety instructions herein.

CAUTION

- The Controllers must be connected to an electrical installation fitted with a type TT earthed socket in compliance with ruling 88-1056 of 14th November, 1988 (for French regulation).
- Our products are designed to meet all CEE regulations in effect. Any modifications by the user are liable to break compliance with regulations and jeopardise the EMC (Electromagnetic Compatibility) performance and product safety. The manufacturer renounces all responsibility for the consequences of any such intervention.

CAUTION

The EMC performance of this product is obtained only if the installation is carried out in compliance with the applicable EMC rules. In particular, in environments liable to emit strong EM disturbances, you must

- use shielded cables and connections for the interfaces
- protect the power line by a shielding from the power source to within 3 metres of the power input to the product.

CAUTION

The enclosure is designed to ensure normal safety conditions in its normal operating environment (in a rack). When used on a table, or when handling the enclosure make sure no objects are introduced into the ventilation holes and that these holes are not blocked.

WARNING

When switching off equipment containing condensers charged at more than 60 VDC or 25 VAC, take all necessary precautions to protect against contact with the pins on the connectors (single phase motors, equipment with mains filter, frequency inverter, monitor, etc.)

- A Commissioning
- B Product description
- C Settings
- D Test mode
- E RS232 mode
- F Appendices

General safety rules

CAUTION

This product's safety and performance can not be guaranteed unless it is used in compliance with this manual.



This symbol on the controller body indicates that certain internal components are under voltage and can cause electric shock if touched. This symbol recommends that the controller be disconnected from the mains before any work is carried out on it or that the circuit breaker be correctly identified and locked.



This symbol on the controller body indicates a potential risk that could cause significant damage to the equipment and/or installations if instructions are not followed.

Qualification of personnel

Jobs described in this document may be carried out only by staff possessing the appropriate technical training and necessary experience or having been trained to this end by the product owner.

Responsibility and guarantee

The manufacturer's responsibility is lifted and the guarantee voided if the owner or a third party

- fails to observe the instructions in this document,
- uses this product in a way that is not consistent with the manufacturer's intended use,
- modifies this product in any way whatsoever,
- uses the product with accessories not listed in the product documentation.

- A Commissioning
- B Product description
- C Settings
- D Test mode
- E RS232 mode
- F Appendices

Unpacking and storing the controller

Unpacking

Take care in unpacking the equipment and keep its all of the packaging. Make sure there is no shipping damage. If any such damage is noted, take the necessary measures with the carrier and notify the manufacturer if necessary.

In all cases we advise you to keep the packaging (recyclable material) in case the controller needs to be shipped again, or must be stored for a long time.

This product was manufactured in a clean environment and packaged carefully to maintain this cleanliness, we advise you not to unpack the controller until it is at its place of installation.

Remove the equipment manually from its package (weight 1.3 kg). The electrical cables (power cable and gauge connection cables) are shipped in a separate package (see appendix 7).

Storing the controller

CAUTION

The controller can be stored in its original packaging at temperature of -20°C to $+60^{\circ}\text{C}$.

Decontamination and product recycling

In compliance with Directive 2002/96/CE concerning the handling of electrical and electronic equipment waste and Directive 2002/9/CE concerning restrictions on hazardous substances, Adixen products that have reached the end of their service life must be returned to the manufacturer for decontamination and reuse.

The manufacturer's obligation to recover such equipment applies only to complete items of equipment that have been neither modified nor retrofitted and have used only spare parts from Alcatel Vacuum Technology sold by Alcatel Vacuum Technology and including all their assemblies and sub-assemblies.

This obligation does not include the cost of transporting the product to a reprocessing centre, nor the cost of the service which will be invoiced on to the customer.

For all equipment returned to an Alcatel service center, the safety questionnaire at the end of manual (or available online at www.adixen.com) must be filled in and sent to the service center in advance.

- A Commissioning
- B Product description
- C Settings
- D Test mode
- E RS232 mode
- F Appendices

Installation

Assembly, installation

The controller can be placed on a table or mounted in a rack.

Table mounting

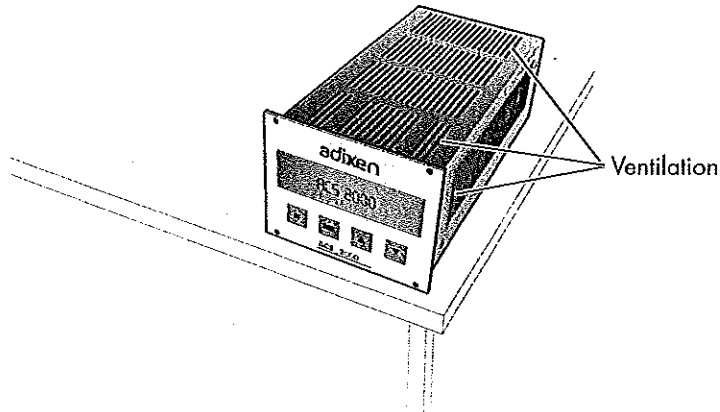

CAUTION

Locate the appliance in a way that ensures good air circulation and avoids direct exposure to the sun.

CAUTION

Controller ventilation
Internal components can deteriorate through overheating if there is inadequate ventilation. **DO not block the ventilation holes.**

Rack mounting

See appendix 3

WARNING

Electric shock hazard.
Before connecting the gauges, set the power switch to the «0» (off) position. Always connect the gauges before switching on power to the controller.

CAUTION

The supply voltage to the unit must be between 100 and 240 VAC. Check the supply voltage and always use adequate cabling. Failure to follow these instructions can lead to electric shock.

A	Commissioning
B	Product description
C	Settings
D	Test mode
E	RS232 mode
F	Appendices

Quick commissioning procedure

Bringing the ACS2000 on line

- 1 - Place the ACS 2000 controller on a table
- 2 - Connect the vacuum gauge to the connection at the back of the controller.
- 3 - Connect the mains power cable

WARNING

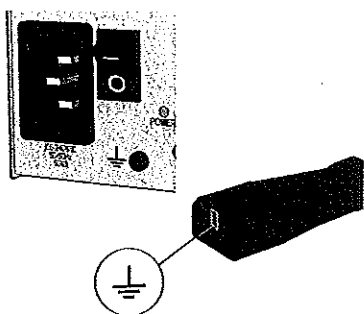

Products which are not properly connected to ground are a danger to life in the event of failure.

The controller frame must be connected to earth and an earth wire is provided for this purposes in the 3-pin power cable (PE). Always connect the power cable to a socket with a ground.

- 4 - Set the power switch to the «1» (ON) position.

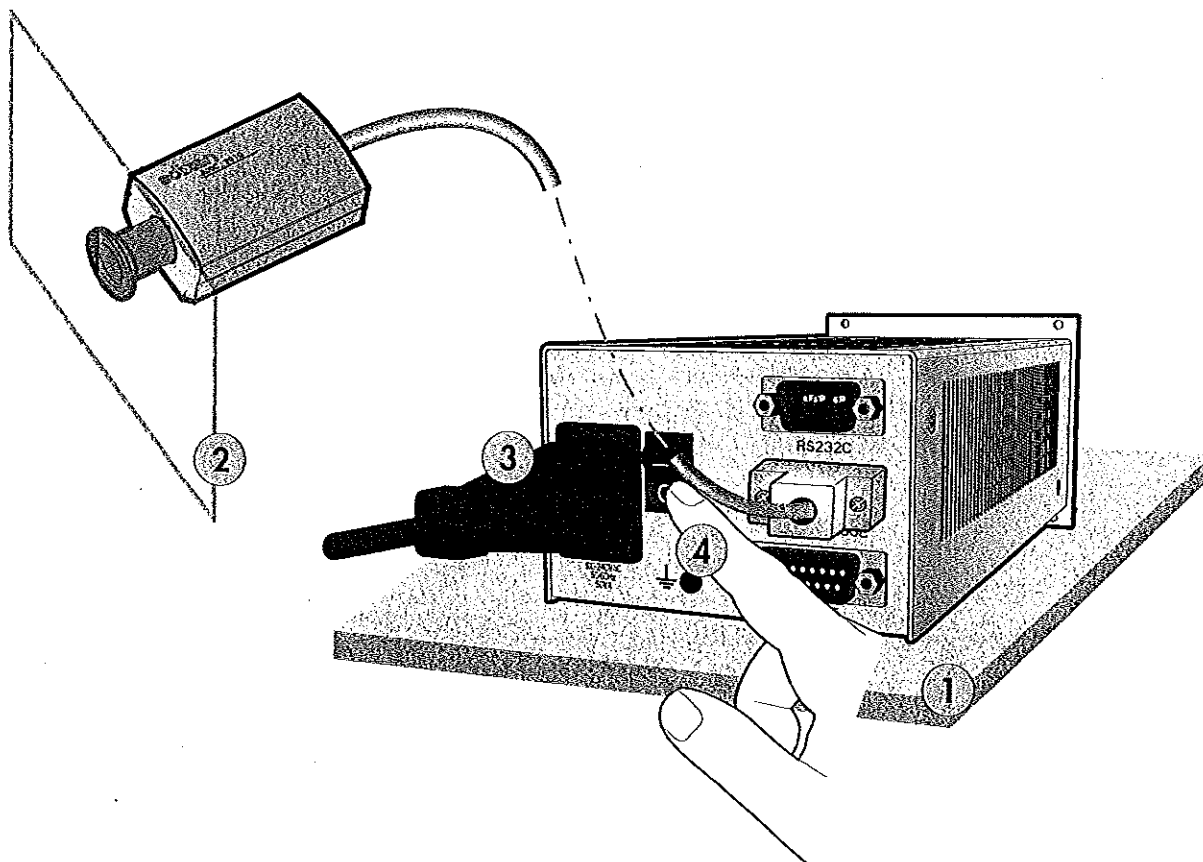

- A Commissioning
- B Product description
- C Settings
- D Test mode
- E RS232 mode
- F Appendices

Quick commissioning procedure

Start-up screen At the start-up and before displaying the measurement screen, the controller performs:

1 - Display test

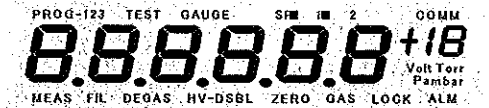

2 - Display of the software version

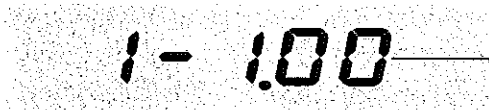

Software version number

3 - Detection of the gauge type

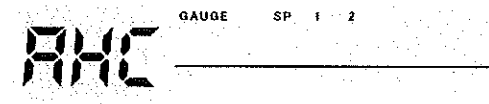

Type of gauge

- AP
- ACC
- AHC
- AD

Restores the parameters that were set before power was turned off, or adapts the parameters if the gauge has changed.

Measurement screen and display

The measurement is available if:

- The gauge is properly connected
- The pressure lies within the measuring range of the connected gauge

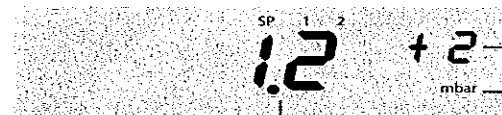

Exponent

Unit

Measurement readout

E.g., the "AHC" type gauge measures a pressure of 1.2×10^2 mbar.

Note From the measurement screen, it's possible to identify what gauge is connected by pressing the button Enter.

- A Commissioning
- B Product description
- C Settings
- D Test mode
- E RS232 mode
- F Appendices

Quick commissioning procedure

Warning or error messages

The following warning message comes up when no gauge is connected.



noGauge

An error message is displayed when an error is detected at controller start-up - see Appendix 6 for the error message list.



Err01

Shutting down

Switch off the ACS 2000 by setting the power switch to the «O» position (or via the distribution box if rack mounted).

CAUTION

Before switching the ACS 2000 on again, wait at least 10 seconds to allow it to reset.

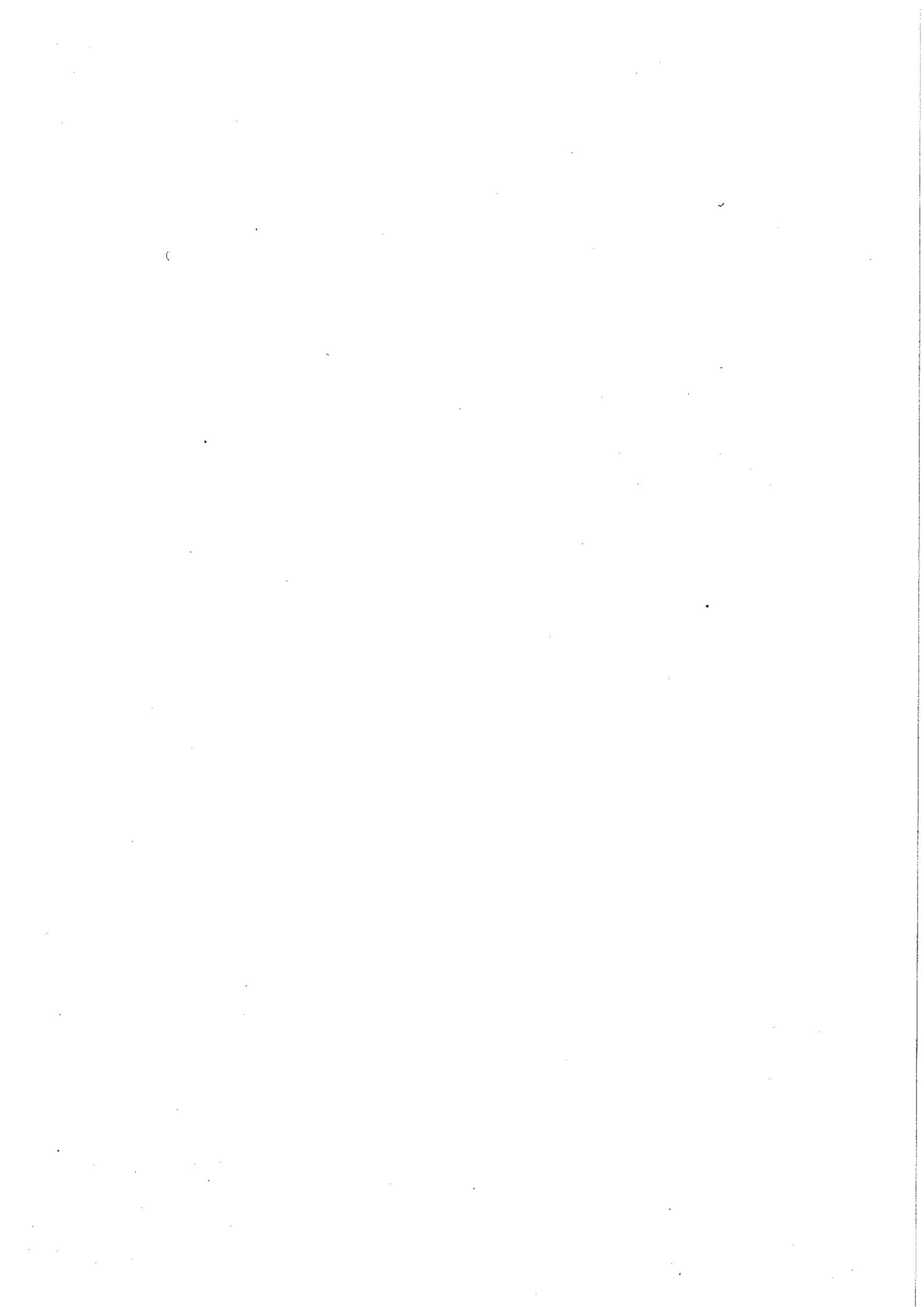

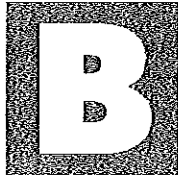

Product description

ACS 2000 User's Manual Detailed contents

Overview of the single-channel controller

2/5

- Controller concept
- Rear view of controller
- Control panel
- Description of display

Navigation controls

5/5

- Buttons

- A Commissioning
- B Product description**
- C Settings
- D Test mode
- E RS232 mode
- F Appendices

Overview of the controller

Controller concept

The ACS 2000 provides power, control, and pressure display for the operation of a gauge. It can be controlled by an operator via the front panel, or externally by a computer via the built-in RS232 link.

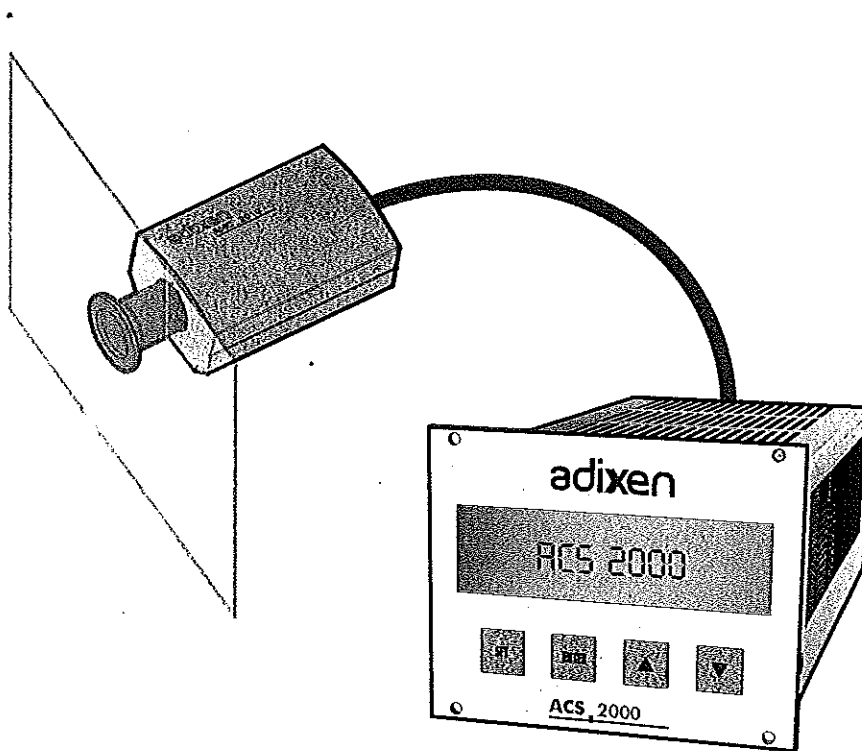

GB 03434 - Edition 02 - September 07

- A Commissioning
- B Product description
- C Settings
- D Test mode
- E RS232 mode
- F Appendices

Overview of the controller

Rear view of controller

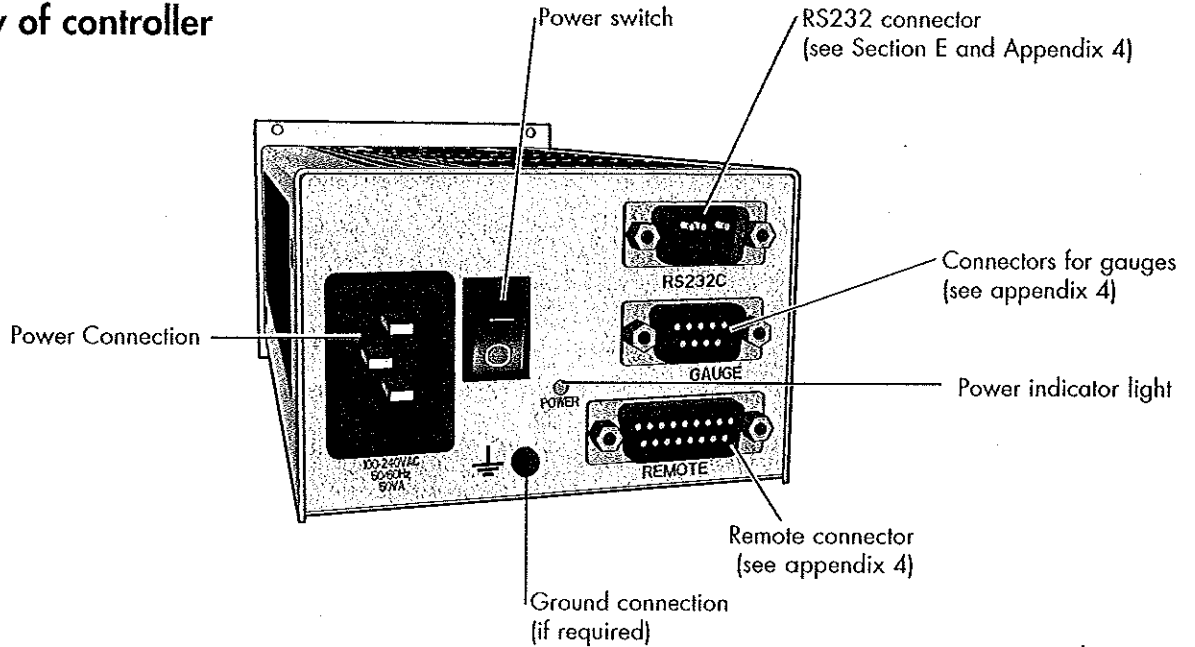

Rear face

Control panel The ACS 2000 is operated from the front face of the enclosure which includes touch buttons and a display.

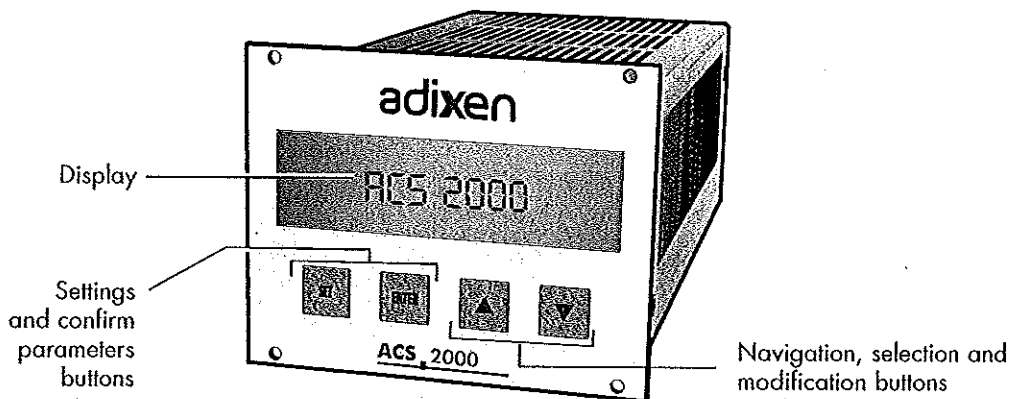

Front face

- A Commissioning
- B Product description**
- C Settings
- D Test mode
- E RS232 mode
- F Appendices

Overview of the controller

Description of display

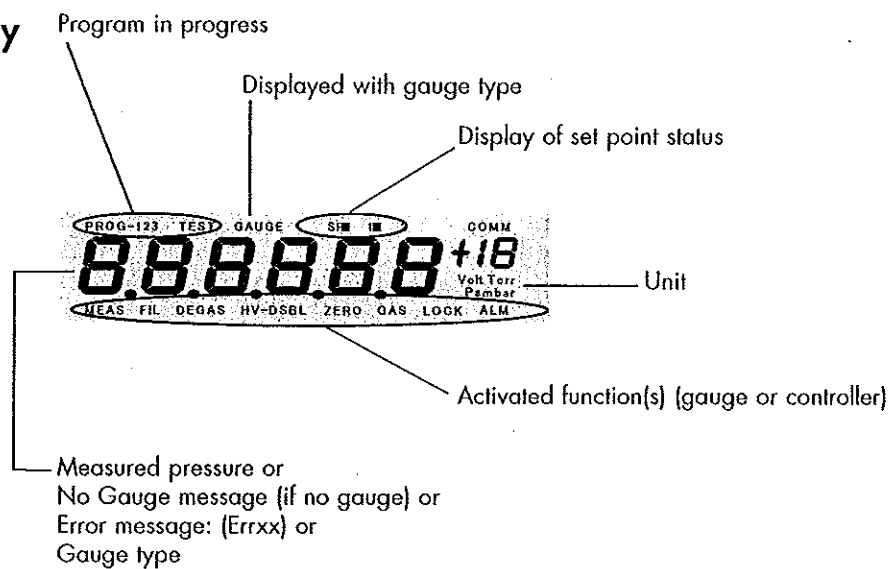













- A Commissioning
- B Product description**
- C Settings
- D Test mode
- E RS232 mode
- F Appendices

Navigation controls

You can navigate through the controller settings using the buttons. Only the buttons are described below. Refer to appendix 10 if you would like a detailed example of how to navigate.

Buttons

  0,5 s	<ul style="list-style-type: none"> ■ Access to SETTING functions. ■ Back to previous menu up to DISPLAY screen.
  2 s	On a SETTING screen: <ul style="list-style-type: none"> ■ Back to DISPLAY screen.
  3 s	On the measurement screen: <ul style="list-style-type: none"> ■ Access to TEST MODE.
 	<ul style="list-style-type: none"> ■ Validation button ■ On the measurement screen, display gauge type.
   	<ul style="list-style-type: none"> ■ These buttons are used to navigate the menus, select variables, change the variables.

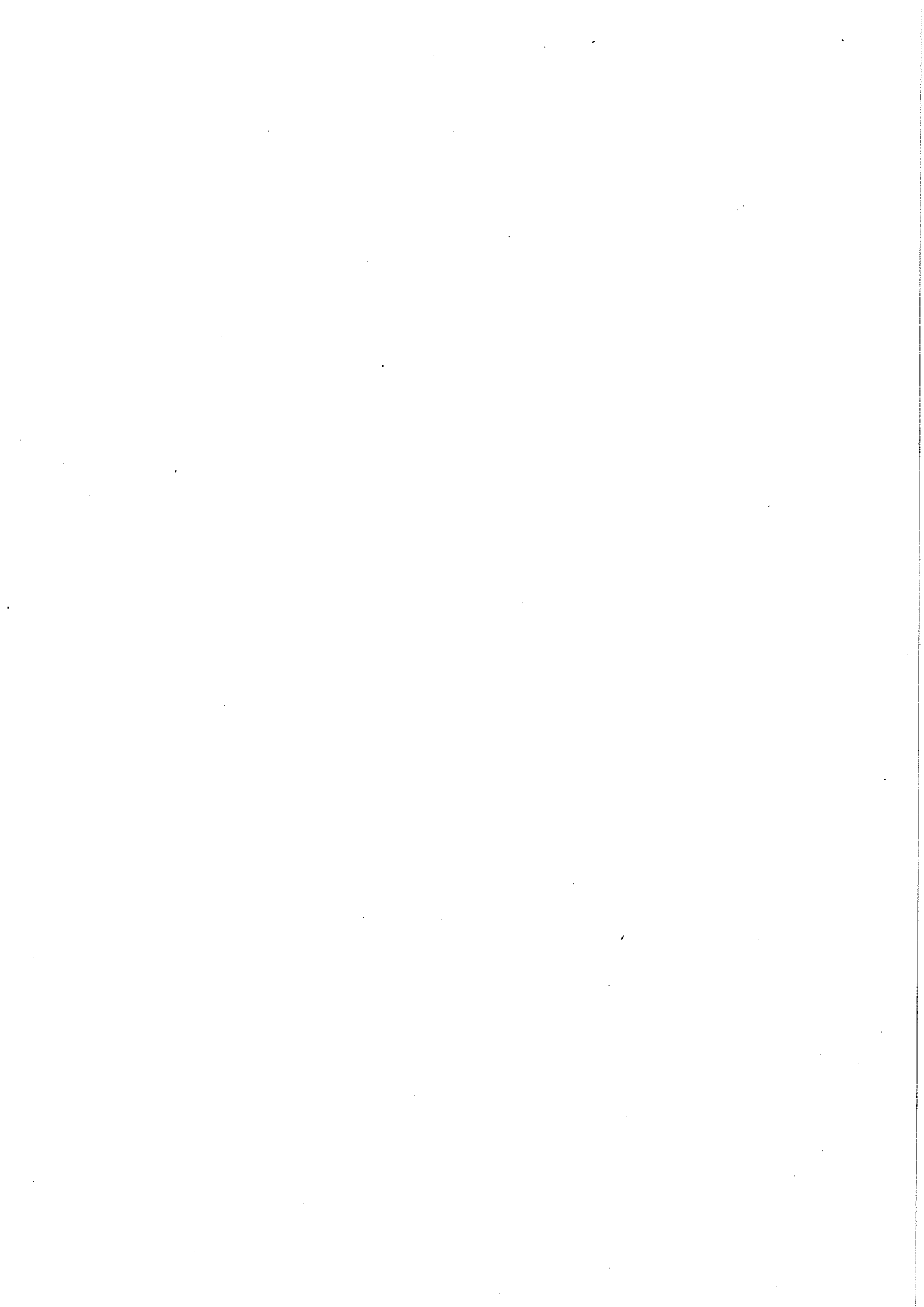

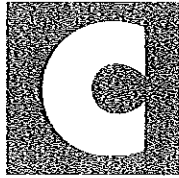

ACS 2000 User's Manual Detailed contents

Overview	2/14
<ul style="list-style-type: none">- Access to settings- List of available settings	
Configuring the gauges	4/14
<ul style="list-style-type: none">■ General settings<ul style="list-style-type: none">- "Gas" correction factor- Analog gauge output■ Specific settings<ul style="list-style-type: none">- AP2004 Pirani gauge- ACC 2009 Combined PIRANI/Cold cathode gauge- AHC 2010 Combined CRYSTAL/Hot cathode gauge- ASD 200X - ARD 200X Capacitive gauges	
Set point management	9/14
<ul style="list-style-type: none">- Display- Adjustment by gauge type	
General settings for the ACS 2000	10/14
<ul style="list-style-type: none">- RS232 parameters- Locking the settings- Settings for measurements- Restoring factory default settings- Available remote Inputs/Outputs	

- A Commissioning
- B Product description
- C Settings**
- D Test mode
- E RS232 mode
- F Appendices

This mode gives access to the user settable functions for

- the gauges (prog 1)
- the controller (prog 2).

Access to settings

On the measurement display screen, press the  button to bring up the following screen:

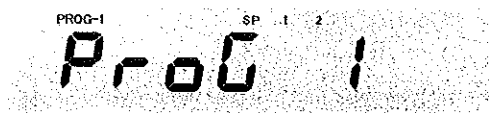

Use the  button to have access to the available parameters for the connected gauge.

Use the button  or  to scroll to next screen.

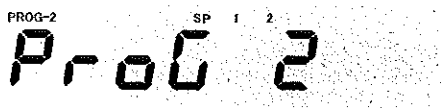

Use the  button to have access to the ACS 2000 controller parameters.

- A Commissioning
- B Product description
- C Settings
- D Test mode
- E RS232 mode
- F Appendices

List of available settings

Prog1	Gauge settings				Menu
	AP 2004 Pirani	ACC 2009 Combined Pirani/ Cold Cathode	AHC 2010, Combined Crystal/ Hot Cathode	ASD 200X ARD 200X Capacitive gauge	
Set points	• • • •	• • • •	• • • •	• • • •	1 - SP1 H 2 - SP1 L 3 - SP2 H 4 - SP2 L
Gas correction factor	•	•	•		5 - GAS
Degaz function			•		6 - DEGS
Off,Set function				•	7 - OFS
Full scale				•	8 - FSR
Hot cathode deactivation function			•		9 - DSBL
Switching function (UR control)		•			10 - URSP
Digit function (5th digit)				•	16 - DIGT

Prog 2	ACS2000 controller	Menu
Digit (2 or 3 digit)	•	1. DIGT
Filtering	•	2. FILT
Unit	•	3. UNIT
Communication speed (baud)	•	4. BAUD
Lock setting	•	5. PLOC
Factory default settings	•	6. FACT
RS232 adjustment	•	7. 232C

- A Commissioning
- B Product description
- C **Settings**
- D Test mode
- E RS232 mode
- F Appendices

Configuring the gauges

General settings



Gas correction factor

This correction factor corrects the measurements from a gauge for gases other than nitrogen (N₂).
The correction factor has an influence on

- the read out
- the switching thresholds of the set points.

This function is available for all gauges except capacitive ones.

- Access to this setting
- 1 - Access : **SET/PROG1/5.GAS**

2 - Press the  button than set the needed value with the button  or .

3- Press  button to confirm.

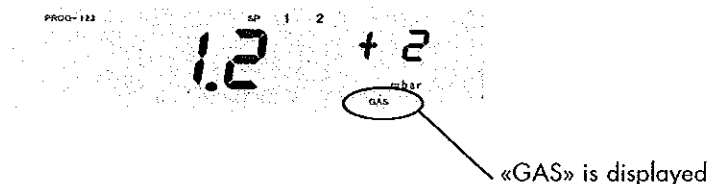

- Factory default setting
- The calibration factor is factory set to a value of 1.

Analog gauge output

A 0-10 V analog output is available on the Remote connector. Its value is identical to the analog signal delivered by the gauge. See the user manual supplied with the gauge for the voltage to pressure conversion functions and graphs.
See Appendix 4: Wiring up the Remote gauge connector.

A	Commissioning
B	Product description
C	Settings
D	Test mode
E	RS232 mode
F	Appendices

Configuring the gauges

Specific settings

Pirani gauge (AP 2004)

No further settings for this gauge.

Combined PIRANI/ Cold cathode gauge (ACC 2009)

Switching function (UR control).

■ Description

This setting allows the set point contacts for this channel to be held open or closed when the gauge indicates "UR" (Under Range = pressure below the gauge's measuring capabilities).

There are several possible causes of this "UR" indication:

- the pressure really is low
- the cold cathode gauge is not primed
- the gauge is faulty.

■ ON setting

Choose ON if you consider it abnormal for the gauge to have gone UR. The set point contacts will then be opened.

■ OFF setting

Choose OFF if you consider it normal for the gauge to have gone UR. The set point contacts will then remain closed.

■ Access to this setting

Access : **SET/PROG1/10.URSP**

■ Factory default setting

The switching function is **ON** by default.

- A Commissioning
- B Product description
- C **Settings**
- D Test mode
- E RS232 mode
- F Appendices

Configuring the gauges

Specific settings

Combined CRYSTAL/ Hot cathode gauge (AHC 2010)

Degassing function

■ Description

Deposits on the electrode system of an AHC 2010 combined CRYSTAL/Hot cathode gauge can effect the measured values or make them unstable.



Degassing involves heating the electron collector grid to 70°C by electronic bombardment, thus cleaning the electrode system. Degassing normally lasts 3 minutes but can be interrupted prematurely.



■ Activating the degassing function:

-> via the controller

1 - Access : **SET/PROG1/6. DEGS**

2 - Press on the button , then . While degassing is in progress (approx. 3 minutes),

- "Degas" is displayed on the measuring screen,
- ignore the displayed pressure values which will be wrong during this operation.

-> via the Remote connector (DEGAS wiring - see Appendix 4))

Note: degassing is impossible when

- degassing has just stopped after 3 minutes
- the pressure is greater than 5×10^{-3} mbar
- «HV-DSBL» is active.

■ Factory default setting

The "DEGAS" function is deactivated by default, i.e., factory set to **OFF**.

Note: if the «DEGAS» function can't be activated, the «ERR08» message displays. (see Appendix 6 for the error message list).

Hot cathode deactivation function

■ Description

This function deactivates the hot cathode gauge
Only pressure values measured with the CRYSTAL gauge appear.

■ Activating the HV-DSBL function:

-> via the controller

1 - Access : **SET/PROG1/9. DSBL**

2 - Press the button , then . HV-DSBL comes up on the screen.

-> via the Remote connector (HV-DSBL wiring - see Appendix 4)

To reactivate measurement, press «HV-DSBL» again.

■ Factory default setting

The "Hot cathode deactivation function" is deactivated by default, i.e., factory set to **OFF**.



- A Commissioning
- B Product description
- C Settings
- D Test mode
- E RS232 mode
- F Appendices

Configuring the gauges

Specific settings

Capacitive gauge (ASD 200X - ARD 200X)

Digit function

■ Description

This function shows or hides the 5th digit in the displayed pressure.

■ Activating the DIGIT function:

- Access: **SET/PROG1/16. DIGIT**

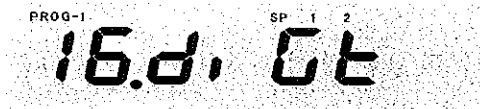

- Press the  button than on the button  or .

■ Factory default setting

The switching function deactivated by default and the display set to **4 digits**.

Zero function

■ Description

This function allows you to assign a measured pressure value as a datum point.

The values displayed will then be negative when the pressure is less than the "ZERO" value entered.

Remark: this is only possible in the voltage range of -0.2V to +0.2V delivered on the gauge's analog output.

■ Activating the ZERO function:

- Access: **SET/PROG1/7.OFS**



Zero is displayed

Note : if the «ZERO» can't be set, th «ERR09» message displays on the screen for 2 seconds. (see Appendix 6 for the error message list).

- A Commissioning
- B Product description
- C Settings
- D Test mode
- E RS232 mode
- F Appendices

Configuring the gauges

Specific settings

Decimal point function

■ Description

This function lets you modify the read out of the displayed pressure value by changing the position of the decimal point. The exponent changes to suit.

■ Accessing this function

- From the measurement screen:

Press on the  button to move the decimal point on the left.

Press on the  button to move the decimal point on the right.

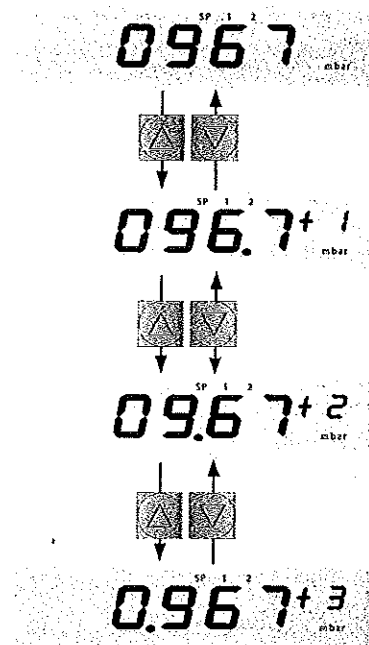

Setting «Full scale»

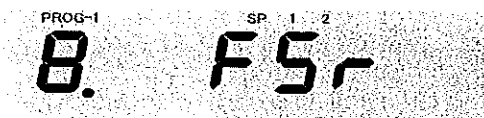

■ Description

This setting specifies the top value in the measuring range depending on the gauge used.



■ Adjusting this setting:

Access: **SET/PROG1/8.FSR**

- Press on the button  or  to modify the value.

■ Factory default setting:

The «Full scale» value is factory set to the highest possible value (1333 mbar).

A	Commissioning
B	Product description
C	Settings
D	Test mode
E	RS232 mode
F	Appendices

Set point management

Setpoint display

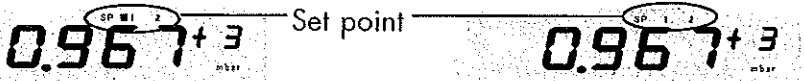

A black square is displayed when SP1 set point is at the «ON» position.

No dot: The set points (SP1, SP2) are at the «OFF» position.

Adjustment by gauge type

The 2 set points are used to control external devices using the "remote" connector. The outputs on the remote connector depend on the setpoint levels programmed and the pressure signal.

Each set point has 2 thresholds:

- 1 low threshold: SP-xL
- 1 high threshold: SP-xH

The setpoint opens as the pressure signal goes below the low threshold and remains open until the pressure signal crosses the high threshold.

CAUTION

To avoid malfunctioning of the open/close contact, the high threshold value must be set at least 10% higher than the low point value.

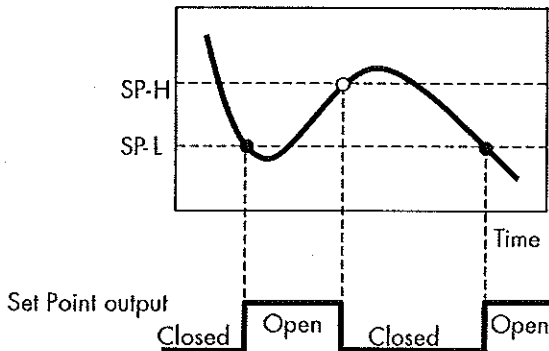

■ Accessing set point adjustment:

Access: **SET/PROG1/1.SP 1H** **SET/PROG1/2.SP 1L**

Access: **SET/PROG1/3.SP 2H** **SET/PROG1/4.SP 2L**

Pressure adjustment range for set points and initial setting for each type of gauge

Gauge	Units	max setting	$\geq(\text{SP-H}) \geq (\text{SP-L}) \geq$	min setting	Initial setting
AP 2004 Pirani	Pa	1.00E+5	$\geq(\text{SP-H}) \geq (\text{SP-L}) \geq$	5.00E-2	5.00E-2
	Torr	750		3.75E-4	3.75E-4
	mbar	1000		5.00E-4	5.00E-4
AHC 2010 Crystal Hot cathode	Pa	1.00E+5	$\geq(\text{SP-H}) \geq (\text{SP-L}) \geq$	5.00E-8	5.00E-8
	Torr	750		3.75E-10	3.75E-10
	mbar	1000		5.00E-10	5.00E-10
ACC2009 Cold cathode	Pa	1.00E+5	$\geq(\text{SP-H}) \geq (\text{SP-L}) \geq$	1.00E-7	1.00E-7
	Torr	750		7.50E-10	7.50E-10
	mbar	1000		1.00E-9	1.00E-9
ASD/ARD Capacitive	Pa	FSx100	$\geq(\text{SP-H}) \geq (\text{SP-L}) \geq$	(FSx100)/1000	(FSx100)/1000
	Torr	FSx0.75		(FSx0.75)/1000	(FSx0.75)/1000
	mbar	FS		FS/1000	FS/1000

A	Commissioning
B	Product description
C	Settings
D	Test mode
E	RS232 mode
F	Appendices

General settings for the ACS 2000 controller

RS232 settings Communication speed

■ Description

This setting is used to adjust the communication speed of the RS232 serial interface.

The speed is expressed in Baud units.

■ Accessing this setting:

Access: **SET/PROG2/4. BAUD**

Modification of this setting does not require the controller to be restarted.

■ Factory default setting:

The communication speed is factory set to **9600 bauds**.

RS232 setting

Selecting the end of line characters for the RS232 transmission

■ CR (carriage return) = return to start of line only (with a risk of overwriting the previous data).

■ CR LF (carriage return + line Feed) = advance to start of next line (with no chance of overwriting the previously sent data).

■ Accessing this setting

Access: **SET/PROG2/7. RS232C**

■ Factory default setting:

The controller is factory set to the **CR** position.

Locking the settings

■ Description

This setting stops anyone modifying the configuration.

It is activated when the LOCK setting is ON.

"Err05" will appear anytime anyone tries to modify a setting.

See appendix 6: error messages).

To unlock the settings, set parameter lock to "OFF"

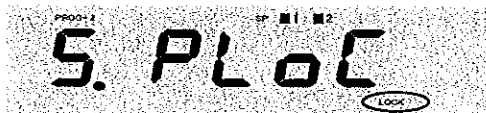

■ Accessing this setting:

Access: **SET/PROG2/5. PLOC**

Modification of this setting does not require the controller to be restarted.

■ Factory default setting

By default the controller is not locked: LOCK is factory set to "OFF".

- A Commissioning
- B Product description
- C Settings**
- D Test mode
- E RS232 mode
- F Appendices

General settings for the ACS 2000 controller

Settings for measurements

Digit

■ Description

This setting lets you chose between 2 or 3 digit display for values.

This setting concerns all gauges except the capacitive gauge.

■ Accessing this setting:

Access: **SET/PROG2/1. DIGIT**

Changing this setting does not require the ACS2000 controller to be restarted.

■ Factory default setting

The pressure display is factory set to 2 digits.

Units

■ Description

This setting lets you choose between the following units for displaying pressure:

- mbar
- Torr
- Pascal

The pressure units are shown in the bottom right of the screen.

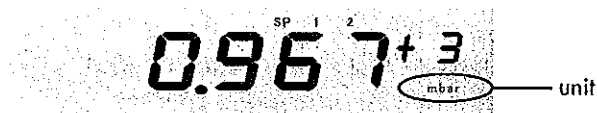

■ Accessing this setting:

Access: **SET/PROG2/3. UNIT**

Changing this setting does not require the ACS2000 controller to be restarted.

■ Factory default setting

The default pressure unit is factory set to **mbar**.

A	Commissioning
B	Product description
C	Settings
D	Test mode
E	RS232 mode
F	Appendices

General settings for the ACS 2000 controller

Filtering

This function smooths the measurement information with a certain frequency response time: Slow/Normal/Fast. This can help with unstable processes or fluctuating measurement signals.

■ Normal filter

Choose the "standard" setting to obtain a good compromise between a fast signal response and a noisy signal, on both the display and the set point functions.

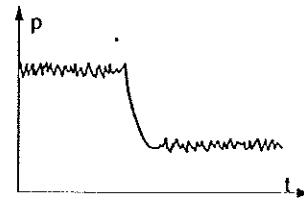

■ Slow filter

Choose "slow" to remove noise from the displayed signal, and to eliminate premature tripping of set points caused by signal noise. The controller will then respond more slowly to variations in the measurement.

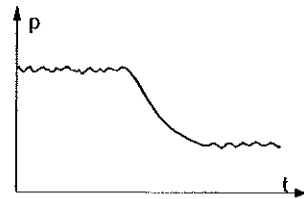

■ Fast filter

Choose "fast" if the read out and set points must respond quickly to measurement fluctuations. The controller will then be more sensitive to measurement disturbances.

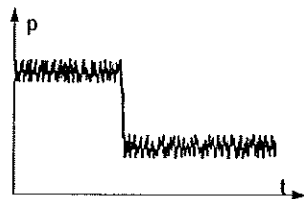

■ Access to this setting:

Access: **SET/PROG2/2. FILT**

■ Factory default setting

This function is set to "NORM".

- A Commissioning
- B Product description
- C Settings**
- D Test mode
- E RS232 mode
- F Appendices

General settings for the ACS 2000 controller

Restoring factory settings

■ Description

This setting causes the ACS 2000 controller to reset all settings their default values (factory default setting).

■ Accessing this setting:

Access: **SET/PROG2/6. FACT**

- Select «ON» and press .

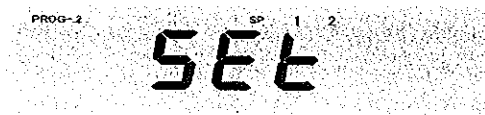

«SET» is flashing during 2 s, the screen the automatically switches to the « 6. FACT » menu

■ Factory default setting

See appendix 5.

Available Remote Inputs/Output Analog recording output

A 0-10 V non configurable analog output is available at the Remote connector (pins 2 & 3). Its value is independent of the type of gauge connected to the channel.

The signal can be used by applying the following formula:

$$\text{output (V)} = 1/2 (\text{Log } P_{\text{disp}} + 12) \quad \text{or} \quad P_{\text{disp}} = 10^{(2 \times \text{output voltage(V)} - 12)}$$

(P_{disp} : value of displayed pressure)

See Appendix 4 for wiring of the Remote connector.

CAUTION

A voltage of 10V, 9.5V, or 0.5V is considered an error.
See list of error messages in Appendix 6.

- A Commissioning
- B Product description
- C Settings**
- D Test mode
- E RS232 mode
- F Appendices

General settings for the ACS 2000 controller

Available Remote Inputs/Outputs (continued) Remote control

The connected gauge can be controlled from the Remote connector.
The criteria controlled depend on the gauge type.

Table of remote control functions

Gauge	Gauge input "function1"	Gauge input "function2"
Pirani AP2004	not used	not used
CRYSTAL/hot cathode AHC2010	DSBL	DEGAS
Cold cathode/Pirani ACC2009	not used	not used
Capacitive ASD200X/ARD200X	no used	not used

See Appendix 4 for wiring of the Remote connector.

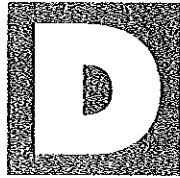

ACS 2000 User's Manual Detailed contents

Access to test mode	2/6
Software version checking	2/6
Analog/Digital converter test	3/6
- Gauge input voltage - Gauge identification resistance	
Controller display test	4/6
Memory test	4/6
- EEPROM test	
Controller interface tests	5/6
- Verification of recorder output voltage - Input/output relay switching test - Testing the front panel buttons - Testing the RS232 link	

- A Commissioning
- B Product description
- C Settings
- D Test mode**
- E RS232 mode
- F Appendices

Access to test mode



You can access the "test mode" by pressing the  button for at least 3 seconds.

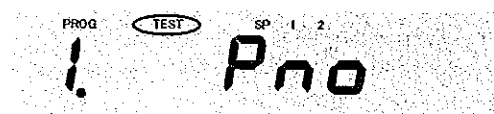

The "TEST MODE" screen comes up.



The controller displays the function 1 of the Test mode: software version checking

Use the   buttons to select which test to perform and press the  button to confirm your choice (see navigation method).

Software version checking

■ Description

This test allows to check the built-in software version.

■ Accessing the menu

Access: **SET/1. PNO**

- Press  button to confirm.
- The controller display the software version.

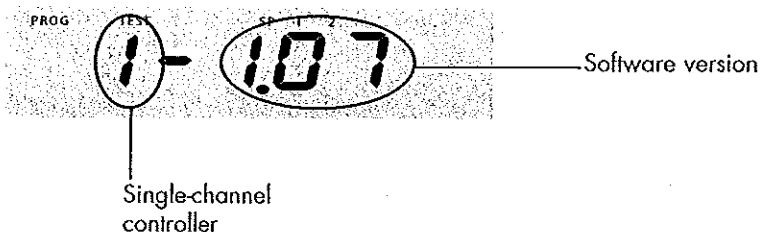

■ Leaving this menu

Press the  button to get back to the previous screen.

A	Commissioning
B	Product description
C	Settings
D	Test mode
E	RS232 mode
F	Appendices

Analog/Digital converter test

Gauge identification resistance

■ Description

Use this test to check the identification resistance from the gauge.

■ Accessing the menu

Access: **SET/2. ADC 1**

- Press  button to confirm.
- The controller displays the value of the identification resistance. This value depends on the type of gauge (see appendix 4).

■ Leaving this menu

Press the  button to get back to the previous screen.

Gauge input voltage

■ Description

Use this test to check the input voltage at the gauge.

■ Accessing the menu

Access: **SET/3. ADC 2**

- Press  button to confirm.
- The controller displays the input voltage for the connected gauge.

■ Leaving this menu

Press the  button to get back to the previous screen.

- A Commissioning
- B Product description
- C Settings
- D Test mode**
- E RS232 mode
- F Appendices

Controller display test

■ Description

Use this test to visually check the display quality.
The controller perform this test by displaying all digits.

■ Accessing this test

Access: **SET/4. Display**

Press  button to confirm.

■ Leaving this test

Press the  button to get back to the previous screen.

Memory test

EEPROM test

■ Description

Use this test to check:
- "Program" memory (EEPROM)

■ Accessing this test

Access: **SET/5. EEP**

Press  to confirm. The program starts up automatically.
«PASS» is displayed to indicated the test has been passed.
«Err» is displayed to indicate the test has failed.

■ Leaving this test

Press the  button to get back to the previous screen.

- A Commissioning
- B Product description
- C Settings
- D Test mode**
- E RS232 mode
- F Appendices

Controller interface tests

■ Description

Use these tests to check



- the output voltage of the channel for recording
- the communication functions of the input/output relays for the channel.
- proper operation of the front panel buttons
- the RS232 protocol.

Verification of recorder output voltage

■ Accessing this test

Access : **SET/6. DAC**

Connect a voltage measuring device to the recorder output.

- Press  button to confirm.
The voltage displayed is 10.0 (Volts) (max value).
- Use the   buttons to select a different output voltage (10V to 0.1V).

Check that the measured voltage is the same as that displayed on the controller.

■ Leaving this test

Press  to get back to the previous screen.

Input/output relay switching test



■ Accessing this test

Access : **SET/7.IO**

 **CAUTION**

The relays can be switched manually, independently of the pressure. It is therefore a good idea to disconnect the cable attached to the Remote connector.

As soon as you press the  button, the SP1 relay switches to the "ON" position.

Use the   buttons to change the output relay states and use an appropriate device to check switching of the relays (ON/OFF).

■ Leaving this test

Press  to get back to the previous screen.

- A Commissioning
- B Product description
- C Settings
- D Test mode**
- E RS232 mode
- F Appendices

Controller interface tests

Testing the front panel buttons

■ Accessing this test

Access: **SET/8.CTRL**

- Press  button to confirm.

Press the various front panel buttons and check that the corresponding names come up on the screen.

Ex:  —> Screen display : «UP»

■ Leaving this test

To leave this test and get back to the previous screen, **press and hold** down the  button.

Testing the RS232 link

Use this test to check the data transfer to and from a computer.

■ Accessing this test

Access : **SET/9.232C**

- Press  button to confirm.

This screen displays 'COMM' while data being transmitted from the computer to the controller.

The transmitted character is resent from the controller to the computer.

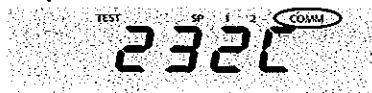

■ Leaving this test

Press the  button to get back to the previous screen.

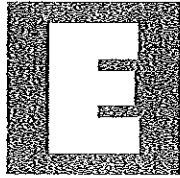

RS232 mode

ACS 2000 User's Manual Detailed contents

Introduction	2/7
<ul style="list-style-type: none">- RS232 interface- Location of the RS232 interface- Configuring the RS232 protocol- Symbols used- Transmission syntax	
List of commands	3/7
<ul style="list-style-type: none">- Interpreting replies- List of commands	
Detailed description of RS232 commands	4/7

A	Commissioning
B	Product description
C	Settings
D	Test mode
E	RS232 mode
F	Appendices

Introduction

RS232 interface

The RS232 interface is used to operate the controller from a computer via an RS232 cable link (see appendix 4)

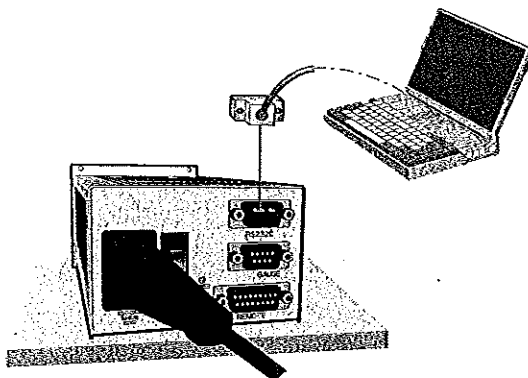

Location of the RS232 interface

The male sub-D 9 pin connector is located on the rear panel of the controller (see chapter B "Overview of single channel controller").

Configuration of RS232 protocol

See the "General settings for the ACS 2000 controller" paragraph in the "Configuration" chapter. Data is transmitted in the following format:

- 8 data bits
- 1 stop bit
- no parity bit.

Symbols used

The following symbols are used in this chapter:

- < > Definition
- [] Option

Transmission syntax

The transmission syntax is as follows:

The order

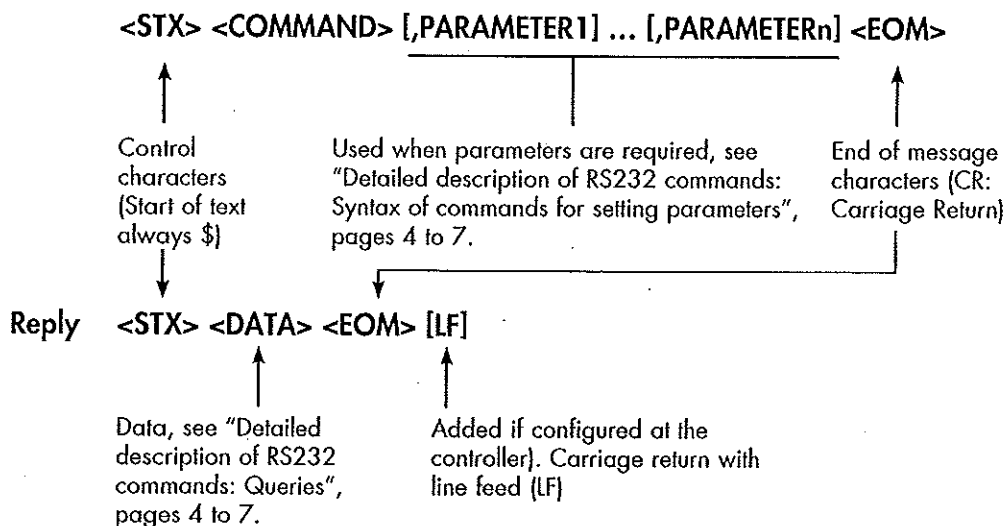

- A Commissioning
- B Product description
- C Settings
- D Test mode
- E RS232 mode**
- F Appendices

List of commands

Interpretation of replies

Reply	Status	Meaning
OK	No error	data received correctly
ERR_00001	Operation error	unauthorised request
ERR_00010	Command error	command wording is incorrect
ERR_00100	Parameter error	parameter value is incorrect
ERR_01000	Transmission error	a transmission error has been encountered
ERR_10000	Hardware error	the controller hardware is faulty

List of commands

Command	Function	Query	Set
BAU	Set transmission speed	■	■
CON	Request continuous reception of pressure value	■	
GAS	Adjust gas correction factor	■	■
DGT	Set number of digits displayed	■	■
DGS	Request degassing function for AHC gauges	■	■
ERR	Status of current errors	■	
FLT	Set filtering	■	■
FSR	Set full scale for AD gauges	■	■
LOC	Lock settings	■	■
OFS	Request 'zero' function for AD gauges	■	■
VER	Query controller software version	■	
PRD	Query pressure value for a channel	■	
SP1	Adjust set point 'SP1'	■	■
SP2	Adjust set point 'SP2'	■	■
SPS	Query set points status	■	
TAD	Test Analogique/Digital converters	■	
TDI	Test display	■	■
TEE	Test EEPROM	■	
TID	Query type of gauge connected	■	
TIO	Test set point relays	■	■
TKY	Test panel buttons	■	
TRS	Test RS232 link	■	
UNI	Set pressure measurement units	■	■
CPF	Set confirmation of power cut	■	■

A	Commissioning
B	Product description
C	Settings
D	Test mode
E	RS232 mode
F	Appendices

Detailed description of RS232 commands

Command	Query	Set	Syntax	Reply	Description
BAU	■		\$BAU,?	\$a	Set or queries RS232 transmission speed a= transmission speed 0 -> 9600 bauds 1 -> 19200 bauds 2 -> 38400 bauds
		■	\$BAU,a	-	
CON	■		\$CON,a	\$b,c	Request continuous reception of pressure value a = reception interval 0 -> 100 ms 1 -> 1 s 2 -> 1 min b= status of gauge 0 -> OK 1 -> Ur 2 -> Or 3 -> Err 03 or Err 04 4 -> not used 5 -> No Gauge 6 -> Id Err 7 -> Err Hi or Err Lo or Err 06 or Err 07 c= measured pressure value for gauges AP, ACC, AHC : x.xxE ± xx for gauge AD: ± x.xxxxE ± xx no gauge: 0.00E+00 Press any button to stop transmission.
GAS	■		\$GAS,?	\$a	Adjust gas correction factor a= adjustment of value to suit gas, from 0.10 to 9.99
		■	\$GAS,a	\$OK	
DGT	■		\$DGT,?	\$a	Set number of digits displayed a= number of digits 2 or 3
		■	\$DGT,a	\$OK	
DGS	■		\$DGS,?	\$a	Request degassing function for AHC gauges a= degassing status for AHC gauge 0 -> OFF 1 -> ON
		■	\$DGS,a	\$OK	
ERR	■		\$ERR	\$ERR_a	Status of current errors a= error code meaning 00000 -> no error 00001 -> operation error 00010 -> command error 00100 -> parameter error 01000 -> syntax error 10000 -> hardware error

GB 03437 - Edition 02 - September 07

- A Commissioning
- B Product description
- C Settings
- D Test mode
- E RS232 mode
- F Appendices

Detailed description of RS232 commands

Command	Query	Set	Syntax	Reply	Description
FLT	■		\$FLT,? [↵]	\$a	<i>Set filtering</i> a= filter 0 -> SLOW 1 -> NORMAL 2 -> FAST
		■	\$FLT,a [↵]	\$OK	
FSR	■		\$FSR,? [↵]	\$a	<i>Set full scale for AD gauges</i> a= full scale for AD gauge 0 -> 1333 mbar 1 -> 133.3 mbar 2 -> 13.3 mbar 3 -> not used 4 -> 1.333 mbar 5 -> not used 6 -> (0,333 mbar) 7 -> not used 8 -> 0,133 mbar
		■	\$FSR,a [↵]	\$OK	
LOC	■		\$LOC,? [↵]	\$a	<i>Lock settings</i> a= status of settings lock 0 -> OFF 1 -> ON
		■	\$LOC,a [↵]	\$OK	
OFS	■		\$OFS,? [↵]	\$a	<i>Request 'zero' function for AD gauges</i> a= zero status of AD gauge 0 -> OFF 1 -> ON
		■	\$OFS,a [↵]	\$OK	
VER	■		\$VER [↵]	\$a	<i>Query controller software version</i> a= software version 1-x.xx
PRD	■		\$PRD [↵]	\$a,b	<i>Query pressure value for a channel</i> a= gauge status 0 -> OK 1 -> Ur 2 -> Or 3 -> Err 03 or Err 04 4 -> not used 5 -> No Gauge 6 -> Id Err 7 -> Err Hi or Err Lo or Err 06 or Err 07 b= measured pressure value for gauges AP, ACC, AHC : x.xxE ± xx for gauge AD: ± x.xxxxE ± xx no gauge: 0.00E+00

- A Commissioning
- B Product description
- C Sellings
- D Test mode
- E RS232 mode
- F Appendices

Detailed description of RS232 commands

Command	Query	Set	Syntax	Reply	Description
SP1	■		\$SP1,?	\$a,b	Adjust set point 'SP1' a= set point low threshold SP1L b= set point high threshold SP1H x.xxE ± xx SP1H >= SP1L
		■	\$SP1,a,b	\$OK	
SP2	■		\$SP2,?	\$a,b	Adjust set point 'SP2' a= set point low threshold SP2L b= set point high threshold SP2H x.xxE ± xx SP2H >= SP2L
		■	\$SP2,a,b	\$OK	
SPS	■		\$SPS	\$a,b	Query set points status a= status of set point SP1 b= status of set point SP2 0 -> OFF 1 -> ON
TAD	■		\$TAD	\$a,b	Test Analogique/Digital converters a= value of analogue signal delivered by the gauge ± xx.xxxV -00.000V if no gauge is connected b= value of the gauge identification resistance xx.xE+3 ohms 00.0E+0 ohms if no gauge is connected
TDI	■		\$TDI,?	\$a	Test display a= screen test status 0 -> OFF 1 -> ON
		■	\$TDI,a	\$OK	
TEE	■		\$TEE	\$a	Test EEPROM a= result of EEPROM test PASS -> OK ERR_ -> error
TID	■		\$TID	\$a	Query type of gauge connected a= gauge connected AP, ACC, AHC, AD or NoGau
TIO	■		\$TIO,a	\$OK	Test set point relays a= state of set point relays 0 -> initial state 1 -> set points 1 and 2 OFF 2 -> set points 1 and 2 ON
		■	\$TIO,a,b	\$OK	

- A Commissioning
- B Product description
- C Settings
- D Test mode
- E RS232 mode
- F Appendices

Detailed description of RS232 commands

Command	Query	Set	Syntax	Reply	Description
TKY	■		\$TKY ↵	\$a	<i>Test panel buttons</i> a= status of command buttons x*** -> SET button *x** -> ENTER button **x* -> ^ button ***x -> v button 0 for OFF, 1 for ON
TRS	■		\$TRS ↵	\$OK	<i>Test RS232 link</i> End of test when 'ETX' ('Ctrl C') is transmitted.
UNI	■		\$UNI,? ↵	\$a	<i>Set pressure measurement units</i> a= pressure measurement units 0 -> Pa 1 -> Torr 2 -> mbar
		■	\$UNI,a ↵	\$OK	
CPF	■		\$CPF,? ↵	\$a	<i>Set confirmation of power cut</i> a= memorise power supply problem 0 -> OFF 1 -> ON
		■	\$CPF,a ↵	\$OK	

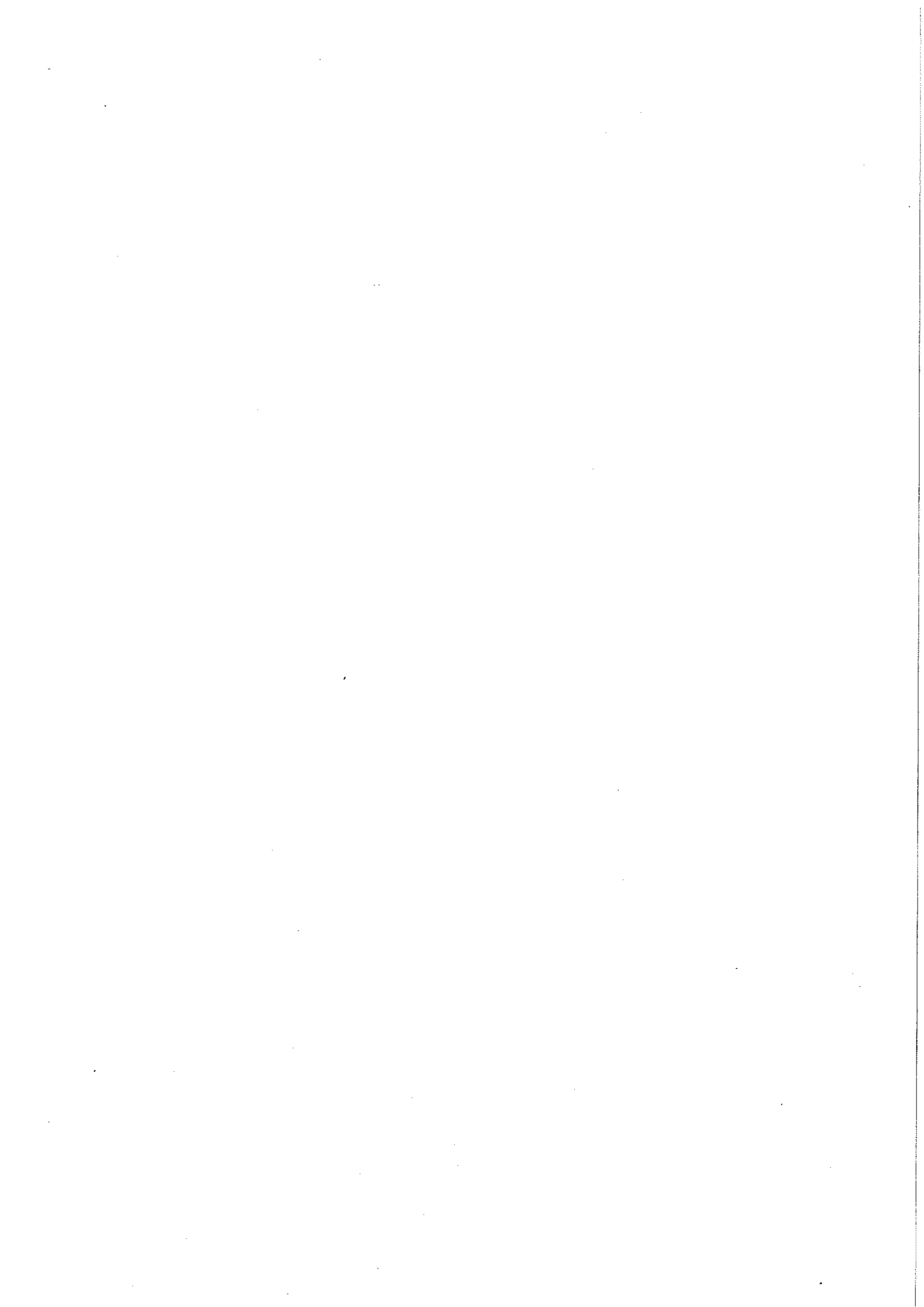

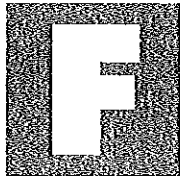

Appendices

ACS 2000 User Manual Detailed contents

<i>Appendix 1: Technical characteristics</i>	<i>2/15</i>
<i>Appendix 2: Dimensions</i>	<i>4/15</i>
<i>Appendix 3: Rack Installation</i>	<i>5/15</i>
<i>Appendix 4: Cable and connector details</i>	<i>6/15</i>
<i>Appendix 5: Factory settings</i>	<i>9/15</i>
<i>Appendix 6: Error messages</i>	<i>10/15</i>
<i>Appendix 7: Accessories</i>	<i>12/15</i>
<i>Appendix 8: Conversion of measuring units</i>	<i>13/15</i>
<i>Appendix 9: Declaration of conformity</i>	<i>14/15</i>
<i>Appendix 10: Detailed example of navigation</i>	<i>15/15</i>

- A Commissioning
- B Product description
- C Settings
- D Test mode
- E RS232 mode
- F Appendices

Appendix 1

Technical characteristics

General specifications	Voltage	100 - 240 V AC
	Frequency	50/60 Hz
	Power requirement	< 50 VA
	Weight	1.3 kg
	Overtoltage category	II
	Protection class	I
Environment	Storage temperature	-20 ... +60 °C
	Running temperature	+5 ... +50 °C
	Relative humidity	< 70 %
	Use	Inside use only, max altitude 2000 metres
	Pollution level	II
	Protection	IP 30
Gauges connected	Number	1
	Usable types	Pirani: AP2004
		CRYSTAL/Hot cathode: AHC2010
		Pirani / Cold cathode: ACC2009
Capacitive: ASD200X-ARD200X		
Sockets	Gauges	D-Sub 9P (female)
	Remote	D-Sub 15P (female)
	RS232	D-Sub 9P (male)
Commands	Front panel buttons	4 buttons
	Rear panel connectors	see "Overview of multi-channel controller" paragraph in this manual
Display	Screen	LCD
	Refresh time	100 ms
Measurement	Measuring range	specific to gauge
	Measurement error	amplifier: $\leq 0.02\%$ of measured signal
		offset: $\leq 0.05\%$ of measured signal
		Filter time constant
	Pressure	mbar, Pa or Torr
	Zero function	Capacitive gauges only
Gauge power supply	Voltage	24 V DC ± 5 %
	Max power requirement (per channel)	13 W
	Current protection	900 mA by resettable fuse
Gauge commands	Number	2 (on gauge connector)
	ON/OFF signal	ON : +24 V, OFF : 0 V

continued on page 3/15

- A Commissioning
- B Product description
- C Settings
- D Test mode
- E RS232 mode
- F Appendices

Appendix 1

Technical characteristics

Remote control power supply	Voltage /Max current	24 V DC \pm 5 % ; 1 00 mA (on Remote connector)
	Current protection	300 mA by resettable fuse
Set Point output	Number	2 (on REMOTE connector)
	Type of contact	Dry contact
	Allowable load	125 V AC, 0.3 A / 30 V DC, 1 A
	Mechanical service life	5×10^7 cycles de commutation
	Electrical service life	1×10^5 cycles de commutation (à charge maxi)
Remote control input	Number	2 (on REMOTE connector)
	Photocoupler input	24 V DC
Analog output	Number	1 (on REMOTE connector)
	Voltage range	- 0.5... 10.5 V
	Accuracy	\pm 50 mV (difference from displayed value)
	Impedance	200 Ω
Recording output	Number	1 (on REMOTE connector)
	Voltage range	0... 10 V
	Precision	\pm 20 mV
	Impedance	200 Ω
Interface (RS232)	Standard	RS232 (RS232 connector)
	Protocol	1 start bit, 8 data bits, 1 stop bit, no parity bit
	RS232	TDX, RXD and GND
	Speed	9600 / 19200 / 38400 Bauds
Standard	CE mark	Low voltage directive: EN61010-1
		EMC directive: EN61326 (Class A emission)

- A Commissioning
- B Product description
- C Settings
- D Test mode
- E RS232 mode
- F Appendices

Appendix 2 Dimensions

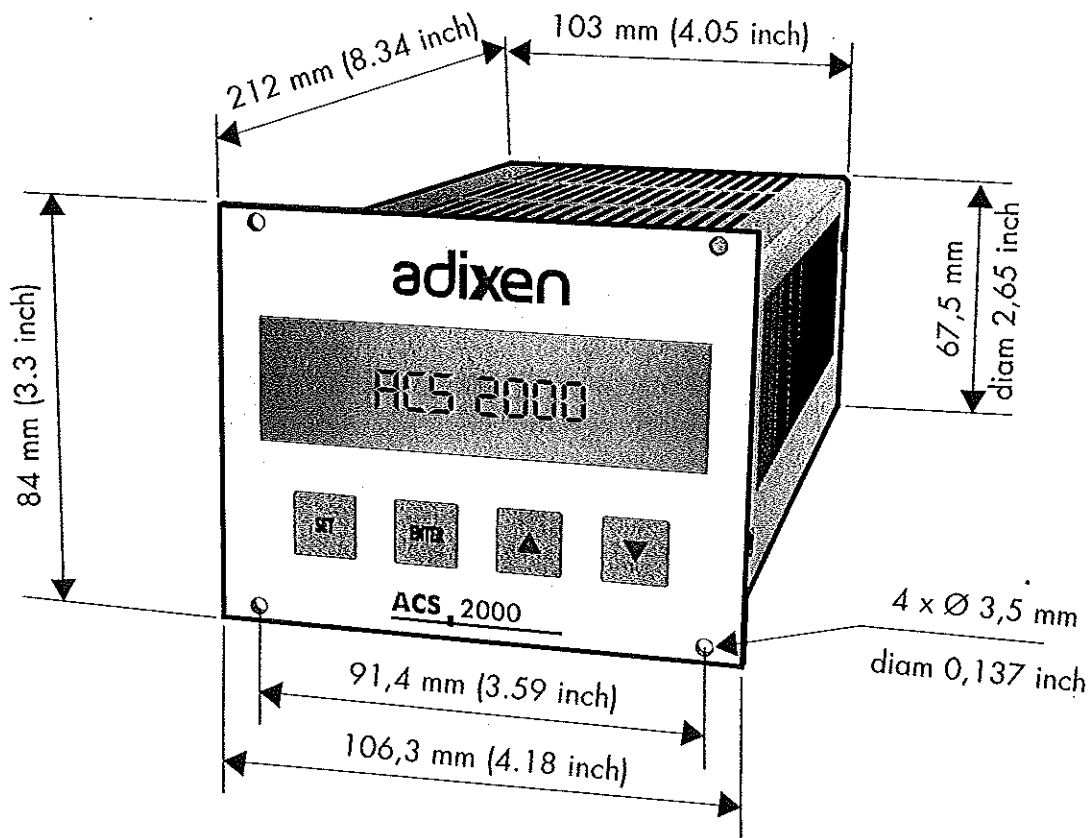

Front panel thickness: 2.5 mm

- A Commissioning
- B Product description
- C Settings
- D Test mode
- E RS232 mode
- F Appendices**

Appendix 3 Rack installation

To optimize space the ACS 2000 controller can be rack mounted. When doing so we recommend you to supply the power through a breaker panel.

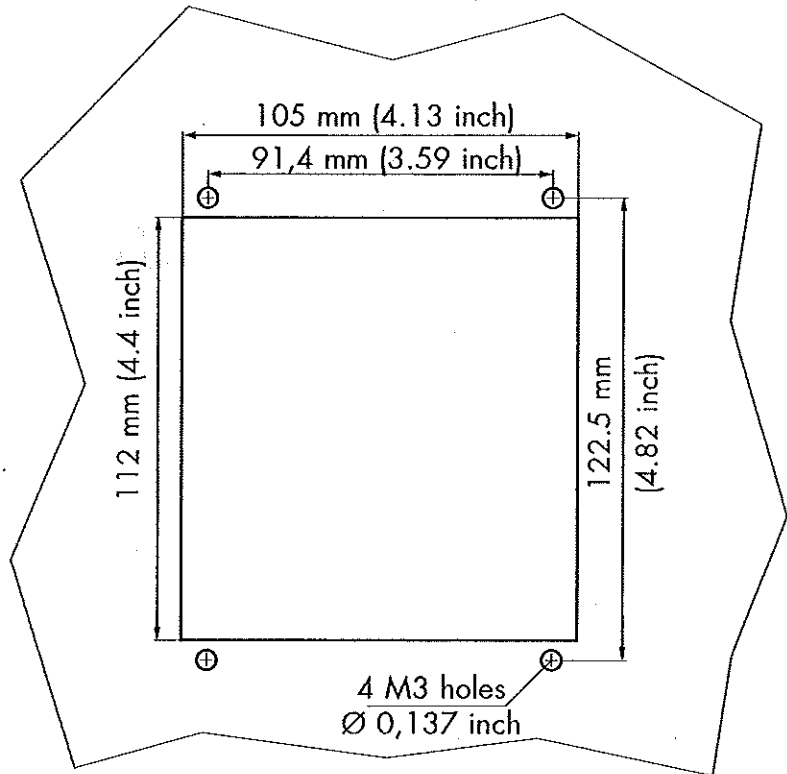

CAUTION

If the controller is rack mounted, the controller temperature will rise and this could cause damage. To avoid this leave 20mm free space around the controller.
In addition, a fan must be installed in the rack to avoid the ambient temperature rising above 50°C.

- A Commissioning
- B Product description
- C Settings
- D Test mode
- E RS232 mode
- F Appendices

Appendix 4

Cable and connector details

WARNING

This controller has dry contact outputs, it is the customer's responsibility to use these outputs in compliance with all appropriate safety standards.

This chapter gives details of the specifications for each connector and the various cable connections.

Gauge connector and gauge cable

CAUTION

Before connecting or disconnecting the gauge cables, always turn the controller power supply off first to avoid causing damage to the equipment.

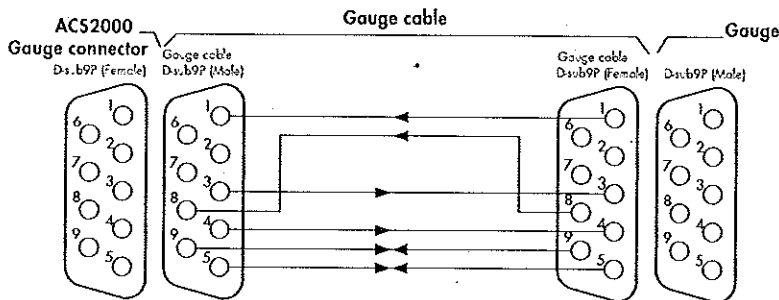

Pin No.	Signal name	Description
1	Measured signal input (+)	Analog signal (+) 0-10 V delivered by the gauge
2	Not used	Not used
3	Gauge "function" output	"DSBL" function for AHC2010 gauge
4	Power supply output (+)	24V DC (+) for power supply to gauge
5	Identification input Gauge "function 2" output	Gauge identification (see table below) "DEGAS" function for AHC2010 gauge
6	Not used	Not used
7	Not used	Not used
8	Measured signal input (-)	Analog signal (-) 0-10 V delivered by the gauge
9	Power supply output	24 V DC (0V) for power supply to gauge

Table of gauge identification resistance values

Gauge	Resistance value
Pirani AP2004	13 K Ω
CRYSTAL/hot cathode AHC2010	4.7 K Ω
Cold cathod/Pirani ACC2009	15 K Ω (DC mode) 18 K Ω (Pirani mode)
Capacitive ASD200X/ARD200X	7.5 K Ω

G8 03438 - Edition 02 - September 07

- A Commissioning
- B Product description
- C Settings
- D Test mode
- E RS232 mode
- F Appendices

Appendix 4 Cable and connector details

“Remote” connector

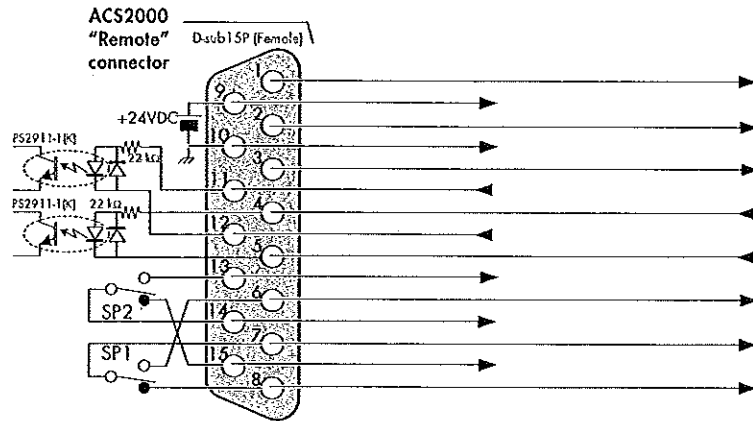

Pin No.	Signal name	Description
1	Measured signal output (+)	Analog signal (+) 0–10 volts delivered by the gauge
2	Output signal (-)	0V of measured signal and recording signal
3	Recording signal output (+)	Analog signal (+) 0–10 volts delivered by the controller
4	Gauge “function 1” (+) input	24 VDC to activate the control
5	Gauge “function 1” (-) input	0 V to deactivate the control
6	Set point (NO)	Set point dry contact
7	Set point common	
8	Set point (NC)	
9	24 V DC power supply output (+)	24 VDC power supply, max 100 mA
10	24 V DC power supply output (-)	
11	Input (+) “function 2” gauge	24 VDC to activate the control
12	Input (-) “function 2” gauge	0 V to deactivate the control
13	Set point 2 (NO)	Set point 2 dry contact
14	Set point 2 common	
15	Set point 2 (NC)	

NO : Normally open

NC: Normally closed

CAUTION

The 24 V DC power supply output is limited to 100 mA. Moreover, it is not isolated from the internal circuit. When the power supply source for the controller is used for the “Remote” or “Set-Point” control, isolation of the photocoupler and relays is no longer guaranteed. To guarantee complete isolation, therefore, use an external power supply.

CAUTION

Before connecting or disconnecting the «Remote» cable, always turn the controller power supply off first to avoid causing damage to the equipment.

Appendix 4 Cable and connector details

- A Commissioning
- B Product description
- C Settings
- D Test mode
- E RS232 mode
- F Appendices

Remote connector (continued) Table of Remote control functions

Gauge	Gauge "function 1" input	Gauge "function 2" input
Pirani AP2004	not used	not used
CRYSTAL/hot cathode AHC2010	DSBL	DEGAS
Cold cathode/Pirani ACC2009	not used	not used
Capacitive ASD200X/ARD200X	not used	not used

CAUTION

In compliance with electromagnetic compatibility standards, use shielded cables for connecting the interfaces. Connect the screening to the chassis earth of the other equipment. Without this, "noise" can be generated which can cause damage to equipment.

CAUTION

Comply with the cut off rating for the set point outputs: 125 V AC - 0.3 A or 30 V DC - 1 A.
Overvoltages and overcurrents can cause internal electrical damage.

Description and connection of RS232 cable

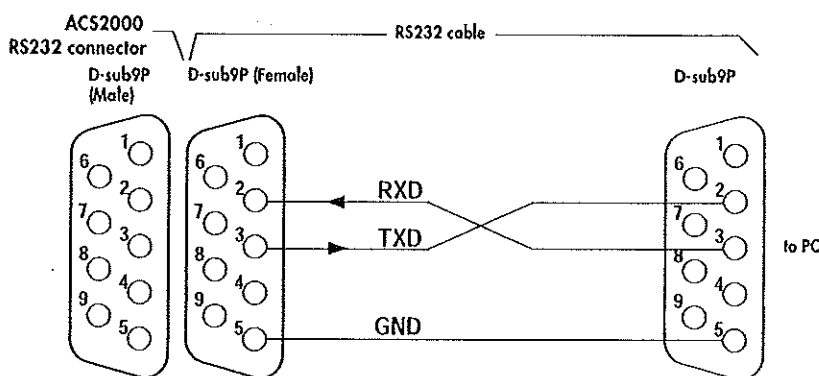

Pin No.	Signal name	Description
2	RXD	Data reception
3	TXD	Data transmission
4	GND	Chassis earth

If the pin number is not described, it is because it is not used.
The RS232 specifications are described in chapter E "RS232 Mode".

- A Commissioning
- B Product description
- C Settings
- D Test mode
- E RS232 mode
- F Appendices

Appendix 5

Factory settings

The values indicated in the table below correspond to factory default settings and can be restored at any time.



You can use the «User value» column to note your own specific settings.

Setting	Default value	User value
Under-Range control	OFF	
Gas setting	1	
Filter setting	NORM	
Full scale setting	1333 mbar	
Digit setting	2 digit	
Unit setting	mbar	
Baud rate setting	9600 bps	
Parameter lock setting	OFF	
RS232 setting	CR	
Set-Point	see "Settings by gauge type" table Chapter C	

Appendix 6

Error messages

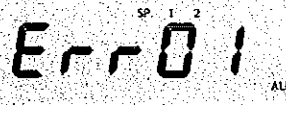
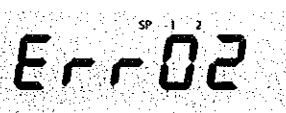
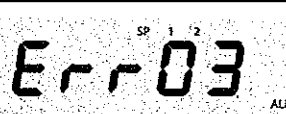
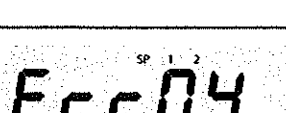
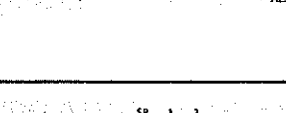

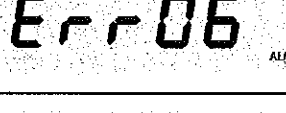
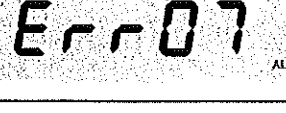
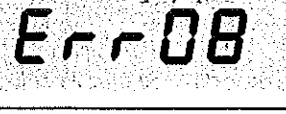
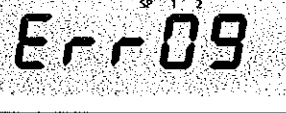

- A Commissioning
- B Product description
- C Settings
- D Test mode
- E RS232 mode
- F Appendices

Error Message	Definition
	<p>Controller error: EEPROM</p> <p>Restore factory settings by pressing ENTER for 3 seconds . «Setting» appears in flashing letters then «SET» is displayed in steady letters. Switch the controller off, wait ten seconds, then switch it back on.</p> <p>An EEPROM fault in the controller is likely if the error persists. Contact customer service.</p>
	<p>Controller error: button activation.</p> <p>A button is activated when a gauge identification error is present.</p> <p>'Err 02' is displayed for 2 seconds.</p>
	<p>Controller error: analog/digital converter CPU card.</p> <p>Pressure measurement stops, set points go to 'OFF', the controller analog output goes to 0.5 V.</p> <p>Switch the controller off, wait 10 seconds, then switch it back on. A controller fault is likely if the error persists.</p> <p>Contact customer service.</p>
	<p>Controller error: analog/digital converter.</p> <p>Pressure measurement stops, the set points go to 'OFF', the controller analog output goes to 0.5V.</p> <p>Switch the controller off, wait 10 seconds, then switch it back on. A controller fault is likely if the error persists.</p> <p>Contact customer service.</p>
	<p>Controller error: locked setting.</p> <p>Attempt to change a setting when the 'Settings lock' is 'ON'. (see 'Settings Lock' function)</p> <p>'Err 05' is displayed for 2 seconds.</p>
	<p>Gauge error: EEPROM or analog/digital converter .</p> <p>Pressure measurement stops, the set points go to 'OFF', the controller analog output goes to 9.5 V.</p> <p>Defective gauge.</p>
	<p>AHC gauge error: Hot Cathode filament or electronics.</p> <p>Pressure measurement stops, the set points go to 'OFF', the controller analog output goes to 9.5 V.</p> <p>Defective gauge.</p>
	<p>AHC gauge error: 'DEGAS' function</p> <p>The degassing function is requested when the required conditions are not present. (see 'DEGAS' function)</p> <p>'Err 08' is displayed for 2 seconds.</p>
	<p>AD gauge error: 'ZERO' function</p> <p>The 'ZERO' function is requested when the required conditions are not present. (see 'ZERO' function)</p> <p>'Err 09' is displayed for 2 seconds.</p>
	<p>Gauge error: the analog signal delivered by the gauge is too high.</p> <p>Pressure measurement stops, the set points go to 'OFF', the controller analog output goes to 9.5 V.</p> <p>Gauge voltage thresholds causing the Hi Err:</p> <p>AP : voltage > 9.5 V</p> <p>ACC : voltage > 9.5 V</p> <p>AHC : voltage > 10.3 V</p>

- A Commissioning
- B Product description
- C Settings
- D Test mode
- E RS232 mode
- F Appendices

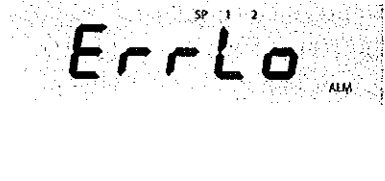
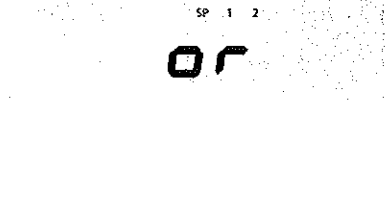
Appendix 6

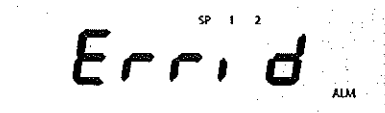
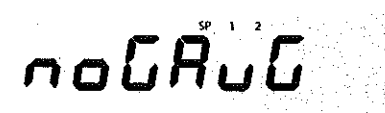
Error messages

	<p>Gauge error: The analog signal delivered by the gauge is too low. Pressure measurement stops, the set points go to 'OFF', the controller analog output goes to 9.5 V. Gauge voltage thresholds causing the Lo Err; AP : voltage < 0.2 V ACC : voltage < 0.2 V AHC : voltage < 0.1V</p>
	<p>Gauge 'Over range' message: the pressure is higher than the maximum value the gauge can measure. Gauge voltages causing 'Or' display: AP : 8.582 V < voltage < 9.5 V ACC : 8.645 V < voltage < 9.5 V AHC : 10.061 V < voltage < 10.3 V AD : 10.5 V < voltage</p>
	<p>Gauge 'Under range' message: the pressure is lower than the minimum value the gauge can measure. Gauge voltages causing 'Ur' display: AP : 0.5 V < voltage < 2.99 V ACC : 0.5 V < voltage < 1.8 V AHC : 0.5 V < voltage < 0.774 V AD : voltage < - 0.5 V</p>
	<p>Gauge error: identification. The gauge is not recognised by the controller. Gauge or gauge cable defective.</p>
	<p>Gauge message: no gauge connected. The set points are 'OFF', the controller analog output is 10 V.</p>
	<p>* Error messages except 'Or', 'Ur' and 'No Gauge' are displayed in blinking letters.</p>

- A Commissioning
- B Product description
- C Settings
- D Test mode
- E RS232 mode
- F Appendices

Appendix 7 Accessories

Power sockets and cables

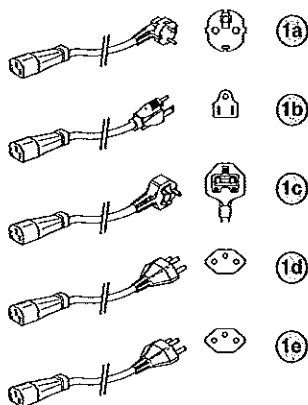

Item	Description	P.N
1a	mains cable - Europe - 2m	103566
1b	mains cable - US+Japan - 2m	103567
1c	mains cable - UK - 2m	104411
1d	mains cable - Switzerland - 2m	103718
1e	mains cable - Italy - 2 m	104758

Gauge cables

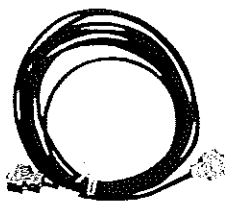

Length	P.N
5 m	112752
10 m	112753
20 m	112754

Adapter kit series 1000/ series 2000 measuring range

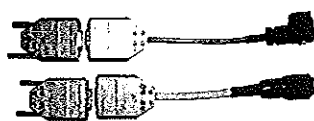

Description	P.N
Gauge adapter	113152
Controller adapter	113153

- A Commissioning
- B Product description
- C Settings
- D Test mode
- E RS232 mode
- F Appendices

Appendix 8

Conversion of measuring units

Weight

	kg	lb	slug	oz
kg	1	2.205	68.522×10^{-3}	35.274
lb	0.454	1	31.081×10^{-3}	16
slug	14.594	32,174	1	514,785
oz	28.349×10^{-3}	62.5×10^{-3}	1.943×10^{-3}	1

Pressure

	N/m ² , Pa	bar	mbar	Torr	at
N/m ² , Pa	1	10×10^{-6}	10×10^{-3}	7.5×10^{-3}	9.869×10^{-6}
bar	100×10^3	1	10^3	750.062	0.987
mbar	100	10^{-3}	1	750.062×10^{-3}	0.987×10^3
Torr	133.322	1.333×10^{-3}	1.333	1	1.316×10^{-3}
at	101.325×10^3	1.013	1.013×10^3	760	1

Vacuum technique pressure units

	mbar	Pascal	Torr	mmH2O	psi
mbar	1	100	750.062×10^{-3}	10.2	14.504×10^{-3}
Pascal	10×10^{-3}	1	7.5×10^{-3}	0.102	0.145×10^{-3}
Torr	1,333	133,322	1	13.595	19.337×10^{-3}
mmH2O	9.81×10^{-2}	9.81	7.356×10^{-2}	1	1.422×10^{-3}
psi	68.948	6.895×10^3	51.715	703	1

Length

	mm	m	inch	ft
mm	1	10^{-3}	39.37×10^{-3}	3.281×10^{-3}
m	103	1	39.37	3.281
inch	25.4	25.4×10^{-3}	1	8.333×10^{-2}
ft	304.8	0.305	12	1

Temperature

	Kelvin (K)	Celsius (°C)	Fahrenheit (°F)
Kelvin (K)	1	$^{\circ}\text{C} + 273,15$	$(^{\circ}\text{F} + 459,67) \times 5/9$
Celsius (°C)	$\text{K} - 273,15$	1	$5/9 \times ^{\circ}\text{F} - 17,778$
Fahrenheit (°F)	$9/5 \times \text{K} - 459,67$	$9/5 \times (^{\circ}\text{C} + 17,778)$	1

Appendix 9

Declaration of conformity

- A Commissioning
- B Product description
- C Settings
- D Test mode
- E RS232 mode
- F Appendices

DECLARATION OF CONFORMITY

We, Alcatel Vacuum Technology France,
98, Avenue de Brogny, BP 2069
74009 ANNECY FRANCE

ISO 9001 CERTIFIED

declare under our sole responsibility that the following Adixen products

ACS 2000 Single channel controller
ACM 2000 Three channel controller

to which this declaration relates are in conformity with the following European Directives

89 / 336 / EEC	Electromagnetic Compatibility Directive
73 / 023 / EEC	Low Voltage Directive
93 / 68 / EEC	Council directive (E.C Marking)
2002/96/ EEC	Waste of electrical and electronical equipments
2002/95/ EEC	Restriction of Hazardous substances

The standards, normative documents, and/or specifications to which the products comply are :

NF EN 61000-6-2	EMC / Generic immunity standard - Industrial environments
NF EN 61000-6-3	EMC / Generic emission standard / Light industry
NF EN 61010-1	Safety requirements for electrical equipment for measurement, control and laboratory use
NF EN 61326 Class A emission)	EMC/ Electrical equipment for measurement, control and laboratory use

Mr J.Y. GUEGAN, Président Directeur Général

Annecy, le 24/08/07

- A Commissioning
- B Product description
- C Settings
- D Test mode
- E RS232 mode
- F Appendices

Appendix 10

Detailed example of navigation

(Adjusting a set point)

